

Oil Pumps (Internal gear pumps)

TRP

TERAL



50Hz/60Hz



Pump overview	Features/Applications/ Specification Items	Precautions for use	Model list	Quick reference table of motor output and maximum working pressure
P.1	P.2	P.3	P.8	P.9

Flow rate Pressure	Small flow rate	Medium flow rate	Large flow rate
Low pressure	A_{Type} P.10 Small flow, low pressure Pump only		
	MA_{Type} P.12 Small flow, low pressure Equipped with motor		
	B_{Type} P.30 Small flow, low pressure (reversible type) Pump only		
		BH_{Type} P.31 Medium flow, low pressure (reversible) Pump only	
Medium pressure	MS_{Type} P.34 Small flow, low pressure Equipped with motor (3-phase 25W)		
		HG/HA_{Type} P.16 Medium flow, medium pressure Pump only	
		MHG/MHA_{Type} P.20 Medium flow, medium pressure Equipped with motor	
			HC_{Type} P.24 Large flow, medium pressure Pump only
			MHC_{Type} P.27 Large flow, medium pressure Equipped with motor
	E_{Type} P.32 Small flow, medium pressure Pump only		

Relief valve

P.35

There is no divider between the internal gear and the external gear. This is an internal gear pump with a gear chamber that is only formed by the internal and external gears. The tooth shape of the external gear is an arc, and the tooth shape of the internal gear is formed by the envelope curves of arcs whose center is on the trochoid curve. The external gear (outer rotor) has one more tooth than the internal gear (inner rotor) and rotates in the same direction. When the tooth number of the external gear is assumed to be "Z," the inner tooth is "Z-1." The rotation speed ratio of the internal and external gears is $Z : Z-1$. As the relative speed is extremely small, the tooth profile wear and noise is reduced.

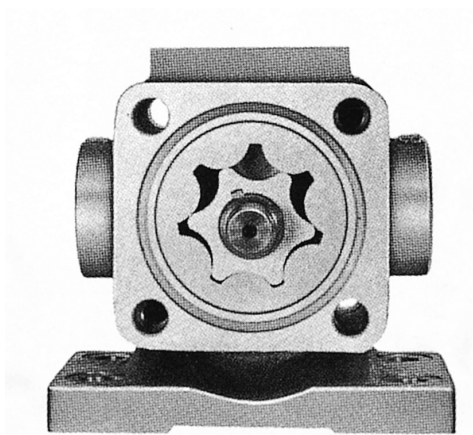
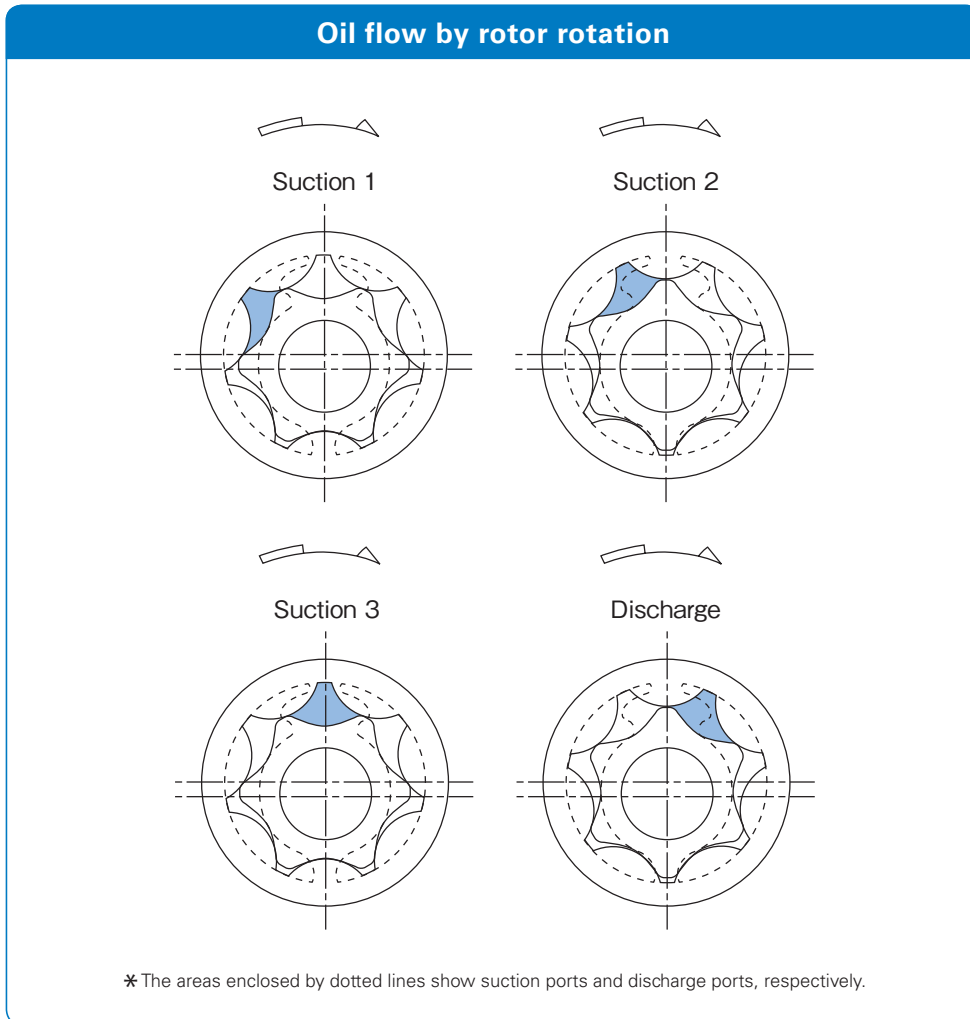

TRP-HG Type, Front

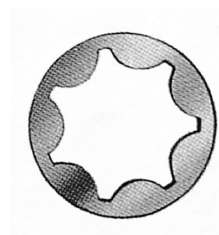

External gear
(Outer rotor)

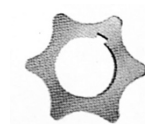

Internal gear
(Inner rotor)

■ Features

① Low cost

Low cost compared to other positive displacement type pumps.

② Easy-to-use and compact

Because it is an internal gear type pump, it is easy-to-use, ideally compact and light in weight compared to other pumps of the same capacity.

③ High volume efficiency

High volume efficiency compared to a gear pump.

④ Easy maintenance

Simple in structure. Also disassembly and inspection is easy.

⑤ Low-noise

Generates low noise characteristic of internal gears compared to gear pumps and other types of pumps.

⑥ Small pulsation

Small pulsation of oil flow compared to external gear pumps.

⑦ Suitable for low speed and high speed

Can be used for any speed from 500 – 2000 rotations per minute.

The maximum rotation speed varies depending on the model. Refer to the model list.

⑧ High suction force

⑨ Wide variation

Choose the volume and model you want. Some replacement parts are compatible.

■ Applications

① Forced-lubrication

Shafts of various machine tools, marine engines, agricultural engines, other engines, for refrigerators, for coolers, for reducers, mining machines, for construction machines, for industrial machines, for forge rolling machines, for press machines, for printing machines, for papermaking machines, for woodworking machines, for iron & steel manufacturing machines, for various generators, compressors, etc.

② Hydraulic drive

Various machine tools, industrial machines, construction machines, printing machines, papermaking machines, agricultural machines, press machines, mining machines, sugar making machines, woodworking machines, etc.

③ For oil transfer

For various machine tools and burner injection, oil facilities, etc.

④ Other

For oil controllers, for various oil filters

■ Specification Items

When making an inquiry about a pump, please specify the following items:

- | | |
|---|--|
| 1.Intended use | Example: forced lubrication or hydraulic drive |
| 2.Type of oil | Example: turbine VG32 |
| 3.Discharge rate (for one minute or one hour) | Example: 5L/min 300L/h |
| 4.Discharge side pressure | Example: 1MPa |
| 5.Rotation speed and driving method | Example: 1750 min ⁻¹ , direct-coupled to the motor |
| 6.Oil temperature during use | Example: 20°C ~ 50°C |
| 7.Rotation direction | Example: left rotation (L) viewed from the pump shaft side
right rotation (R) viewed from the pump shaft side |

For the TRP type, internal gear pump operation under appropriate conditions such as clean petroleum-based hydraulic oil allows for fewer failures and longtime use with lower maintenance costs.

1. Installation of pump

1 Coupling

Incorrect centering may cause shaft seal wear, bearing breakage, shaft damage and noise generation. (For specialized coupling, please consult with our Engineering Division.)

In the case of direct coupling

(A) Joint method (Avoid this method whenever possible as durability low.)

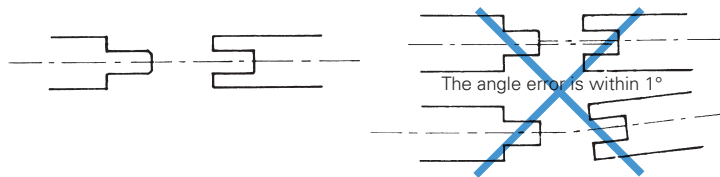

(B) Flexible coupling

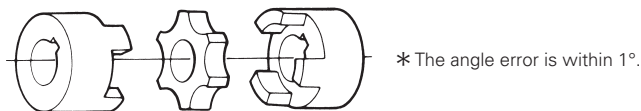

2 Installation site

Make sure to set the pump suction port above the oil level.

(Failure to do so may cause oil leakage from the shaft seal portion.)

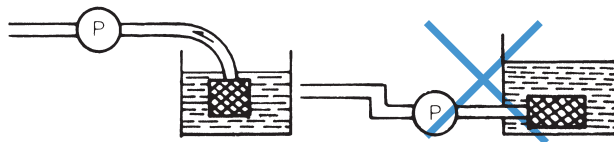

2. Precautions for piping

1 Flow velocity

Select a pipe size so that the average flow velocity in the pipe is less than 1.5m/sec on the suction side and less than 3m/sec on the discharge side (according to the pump bore).

Make the pipe on the suction side as short and straight as possible.

2 Suction pressure

As the resistance on the suction side becomes higher, there is a possibility that the discharge rate will decrease and the noise will increase due to cavitation phenomenon.

Set the suction pressure within the range from -0.03MPa to the atmospheric pressure.

3 Cavitation

When the pressure in the flowing liquid is locally reduced, the containing gas is separated into air bubbles, causing noise and vibration.

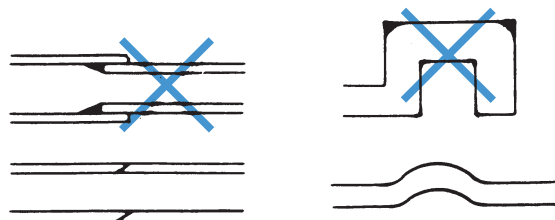

Note: When there must be blanks in the piping because of space, slow the above flow velocity.

4 Piping

- (i) Make sure to seal the connection of the pipes so that there is no air suction and no oil leakage.
- (ii) Pay careful attention so that no foreign matter such as the seal tape or pipe burr enters the pump.
- (iii) Do not screw pipes excessively because the casing will break.
- (iv) Do not apply an excessive force on the pump.

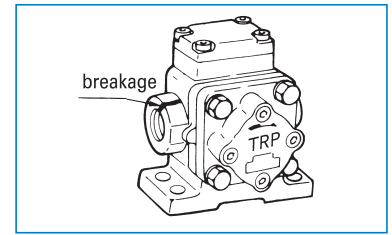

3.Suction strainer

Make sure to install a suction strainer filter on the pump suction side.

- (i) It is appropriate that the filtration accuracy is 100 – 200 mesh.
*When many fine particles are mixed, use a separator, etc., to remove them as much as possible.
- (ii) Clean the strainer periodically. (Consider the structure of the tank so that it can be easily cleaned.)
- (iii) Use a strainer with filtration capacity more than twice as much as the pump discharge rate.

4.Oil tank

- ① Use a tank with a capacity as large as possible.
(The capacity is approximately three times as much as the pump discharge rate (L/min) .)
 - (i) When the tank capacity is smaller than the pump discharge rate, the oil temperature rises to accelerate oil deterioration.
 - (ii) A small amount of oil will cause poor suction.
- ② Prepare an oil level gauge.
- ③ Install a baffle plate between the return pipe and the suction pipe to separate and precipitate air bubbles and foreign matter.
- ④ Separate the return pipe and the suction pipe from each other as far as possible.
- ⑤ Provide a vent mechanism (air breather, etc.) so that the pressure fluctuation in the tank will not increase.

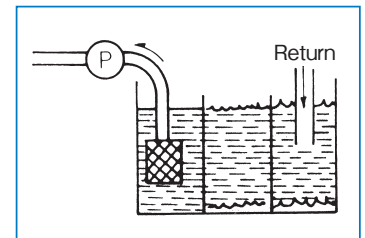

5.Rotation speed of pump

When using high-viscosity (high concentration of) oil, the volumetric efficiency is decreased and the noise of pump becomes larger at a high-speed rotation. In this case, low-speed rotation is desirable. When using the oil of proper viscosity, use low or high speed arbitrarily.

*There is a drain hole on the suction side of the casing. When the pump rotates in the reverse direction, pressure on the discharge side may be applied to the seal portion through the drain hole to damage the seal.

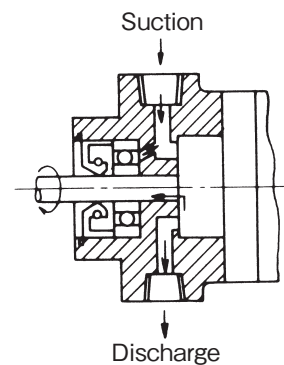

6.Precautions for operation

- ① Manually rotate the pump shaft to confirm whether it can lightly rotate or not.
- ② Make sure to check the rotation direction before operation.
(Reverse direction may damage the oil seal.) (Check it by inching motion)
- ③ When the pump vibrates or generates noise, immediately stop the operation and inspect it again according to the items of maintenance and inspection (p. 6).
- ④ Fully open the valves and cocks in the piping route. In particular, pay careful attention to the suction side because poor suction may occur.
- ⑤ Set the temperature difference between the use oil and the pump casing at the time of start to 40° or less.
When the temperature difference is large, pre-warm the pump to reduce the difference.
- ⑥ Pay careful attention so that the discharge pressure may not exceed the maximum pressure (described in the catalog).

7. Handling of motor

1 Inspection

- Whether the output (kW), pole number (P), type, voltage (V), frequency (Hz), etc., described on the nameplate are as ordered.
- Whether the motor has been damaged by an accident during transportation, etc.

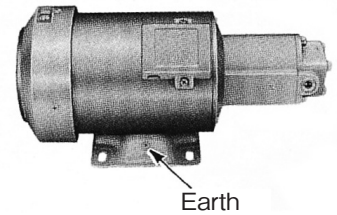

2 Installation

- Install the motor above the oil level.
- Do not install the motor in a location with high humidity and dust. Ensure good ventilation.
- Tightly secure the motor according to the bolt dimensions specified by its manufacturer.

3 Wiring

● Wiring procedure

Perform wiring using excellent tools and equipment according to Electrical Equipment Technical Standards and the regulations of electric power utilities, referring to the table below. Keep in mind that a voltage drop will increase as the wiring distance becomes longer.

[Wiring of motor]

Output (kW)	Excess scale ammeter (A)	Minimum wire thickness *Note 1 (mm)	Minimum grounding wire thickness (mm)	Local fuse capacity (A)	Local switch capacity (A)
0.2	5	1.6	1.6	15	15
0.4	5	1.6	1.6	15	15
0.75	5	1.6	1.6	15	15
1.0	10	1.6	1.6	15	15
1.5	10	1.6	1.6	15	15
2.2	10	1.6	1.6	20	30
3.7	10	2.0	2.0	30	30

(Note) The minimum wire thickness shows the case of storing three wires in metallic pipe wiring.

● Grounding (Earth)

Because the insulator of a motor is both an insulator and a dielectric, a motor has a capacitance between the motor frame and the ground. In the non-grounded case, induced voltage (approx. 50-60% of power-supply voltage) may be generated in proportion to this capacitance. Therefore, make sure to carry out grounding construction for a motor in accordance with Articles 18 – 28 in the Electrical Equipment Technical Standards to prevent an accident due to electric shock. And use the screws for grounding in the terminal box of the motor or at the bottom of its frame (refer to the drawing above.)

● Terminal box

The position of a terminal box can be changed to right/left or top/bottom in steps of 90° by removing the screws in the box. (The position of the terminal box (75W to 400W) can be changed only up and down in steps of 180°)

4 Start

- Whether the connection and ground to the supply are reliably connected.
- Whether the motor rotates in the specified direction (by an arrow). (When the motor starts and stops, it can be confirmed by the fan rotation.) If the motor rotates in the reverse direction (confirm it by inching motion), change two of the three power supplies (in the case of a 3-phase motor).
- Confirm that the valves and cocks in the piping route are fully opened.
- When the motor starts, suction and discharge will start in a few seconds.
- Check the discharge pressure.
When a pressure that exceeds the allowable pressure (described on the nameplate) is detected, immediately stop the running of motor. (Excessive pressure may cause a motor to burn out.)

8.Maintenance and inspection

Periodic maintenance and inspection can extend the life of a pump and prevent an accident.

Perform maintenance and inspection according to the following procedures:

- (i) The pump body does not require a supply of lubricating oil.
- (ii) Clean the strainer as many times as possible depending on the properties of oil.
- (iii) Check the oil temperature (50°C or lower is recommended.).
- (iv) Check the flow rate. Confirm that the pump is operating normally by using a manometer.

9.Problem cause and countermeasures

In the event of trouble, confirm the following items. When the cause cannot be found, please contact us or the dealer.

Main problems		Causes	Countermeasures
1	Insufficient discharge rate	a.Low oil level in tank b.Poor suction c.Poor pump rotation d.Inappropriate oil viscosity e.Misalignment of valves	Increase the oil level by supplying oil. Inspect clogging of the suction pipe and filter and air infiltration. Inspect whether the pump rotation is normal. Check the oil viscosity. Inspect whether there is foreign matter. Adjust the valves.
2	Decrease in pressure	a.Cause for any one of Item 1. b.Large internal leakage c.Large external leakage	Perform according to the countermeasures for cause of Item 1. Inspect the cylinder valve Replace the damaged packing and seal Repair the wear surface Inspect the pump, valve and pipe
3	Pump noise	a.Cavitation b.Damage and looseness of pump parts	Inspect air infiltration, filter clogging, capacity and oil viscosity. Inspect entry of foreign matter, poor lubrication, incorrect installation, etc.
4	Oil leakage	a.Incorrect piping b.Breakage of packing and seal	Inspect whether the pipe connection method is appropriate, whether packing and seal are broken, and whether the materials are appropriate.
5	Irregular operation of valve	a.Entry of foreign matter b.Valve breakage	Inspect entry of foreign matter and breakage due to wear, etc.
6	Overheating of operating oil	a.Oil viscosity is too high b.A small amount of oil in tank c.Excessive relief valve pressure d.Excessive discharge pressure e.Locally narrow circuit	Optimize the viscosity Inspect the oil level } Inspection and adjustment Inspect pipe diameter and valve capacity
7	Irregular machine operation	a.Air infiltration b.Failure of sliding portion and entry of foreign matter	Inspect the sealing of the pipe connection, sliding part and bearing. Inspect excessive tightening of the packing, entry of foreign matter, wear, etc.

10.Spare parts

●Seals

Type	Part Name	Dimensions	Material
A	O-ring	2×32×36	Nitrile rubber
	Oil seal	S8227	Nitrile rubber
HG	O-ring	S56	Nitrile rubber
	Oil seal	S15357	Nitrile rubber
HA	O-ring	S56	Nitrile rubber
	Oil seal	S15357	Nitrile rubber
HC	O-ring	G85	Nitrile rubber
	O-ring	G45	Nitrile rubber
	Oil seal	D254511	Nitrile rubber
B	O-ring	2×39×43	Nitrile rubber
	Oil seal	S8227	Nitrile rubber
BH	Oil seal	S13287	Nitrile rubber
E	O-ring	2×32×36	Nitrile rubber
	O-ring	S26	Nitrile rubber
	Oil seal	D12327	Nitrile rubber
MS	O-ring	S26	Nitrile rubber
	Oil seal	S8227	Nitrile rubber
A-DB	O-ring	P5	Nitrile rubber
H-DB	O-ring	P10A	Nitrile rubber
	O-ring	P18	Nitrile rubber
HC-DB	O-ring	P10A	Nitrile rubber
	O-ring	P18	Nitrile rubber

●Spring specification (When equipped with a motor, a spring must be used within the range of motor capacity.)

A-DB	
Nominal designation	Specification (for MPa)
A-1	0.10~0.30
A-2	0.30~0.60
A-3	0.60~

H-DB	
Nominal designation	Specification (for MPa)
H-1	0.10~0.15
H-2	0.15~0.20
H-3	0.20~0.29
H-4	0.29~0.59
H-5	0.59~1.08
H-6	1.08~2.16
H-7	2.16~3.20

HC-DB	
Nominal designation	Specification (for MPa)
HC-1	0.10~0.20
HC-2	0.20~0.39
HC-3	0.29~0.49
HC-4	0.39~0.78
HC-5	0.59~1.47
HC-6	1.47~2.45
HC-7	1.96~2.94
HC-8	3.43~3.92

All the maximum discharge pressures described in this catalog are displayed based on a viscosity of 56mm²/s (cSt). When the viscosity falls outside of the available viscosity ranges shown on page 37, the performance and durability may vary. Please contact us.

The maximum discharge pressure is 0.49MPa in the case of high-temperature specification, and 0.98 MPa in the case of coolant specification.

Description Type	Theoretical discharge rate (L/min)			Maximum discharge pressure (MPa)	Maximum rotation speed (min ⁻¹)	Bore (Rc)		Approx. mass (kg)								Page	
	1000min ⁻¹	1500min ⁻¹	1800min ⁻¹			IN	OUT	Equipped with motor							Pump only		
								25W	75W	100W	200W	400W	750W	1.5kW			
TRP-MS03	—	0.45	0.54	0.49	Rating	1/8	1/8	4.0	—	—	—	—	—	—	—	—	34
TRP-MS05	—	0.75	0.90	0.49	Rating	1/8	1/8	4.0	—	—	—	—	—	—	—	—	34
TRP-10A	1.0	1.6	1.9	0.49	2000	1/8	1/8	—	6.5	7.0	7.2	—	—	—	0.5	10	

TRP-18A	1.8	2.7	3.2	0.49	2000	1/8	1/8	—	6.5	7.0	7.2	—	—	—	0.5	10
TRP-E18	1.8	2.7	3.2	1.96	2000	1/4	1/4	—	—	—	—	—	—	—	1.2	32

TRP-27A	2.7	4.1	4.9	0.49	2000	1/4	1/4	—	6.5	7.2	7.5	—	—	—	0.7	10
TRP-E27	2.7	4.1	4.9	1.96	2000	1/4	1/4	—	—	—	—	—	—	—	1.2	32

TRP-39A	4.0	6.0	7.2	0.49	2000	3/8	3/8	—	—	7.7	8.0	—	—	—	0.8	10
TRP-E39	4.0	6.0	7.2	1.47	2000	3/8	3/8	—	—	—	—	—	—	—	1.3	32
TRP-45A	4.5	6.8	8.2	0.49	2000	3/8	3/8	—	—	—	—	—	—	—	0.8	10

TRP-HG3	2.8	4.3	5.2	3.2	2000	1/2	1/2	—	—	—	11.0	13.0	20.0	26.0	2.5	16 ~ 19
TRP-HG4	4.1	6.1	7.4	3.2	2000	1/2	1/2	—	—	—	11.0	13.0	20.0	26.0	2.6	
TRP-HG6	6.1	9.2	11.1	3.2	2000	1/2	1/2	—	—	—	11.5	13.5	20.5	26.5	2.8	
TRP-HG8	8.2	12.3	14.8	3.2	2000	1/2	1/2	—	—	—	11.5	13.5	20.5	26.5	2.9	
TRP-HG10	10.3	15.4	18.5	1.96	2000	3/4	3/4	—	—	—	—	14.0	21.0	27.0	3.0	
TRP-HG12	12.3	18.5	22.3	1.96	2000	3/4	3/4	—	—	—	—	14.0	21.0	27.0	3.2	

*When a pressure exceeding the maximum discharge pressure is required, please contact us accordingly.

TRP-HA14	14.8	22.2	26.6	1.96	2000	3/4	3/4	—	—	—	—	14.0	21.0	27.0	3.0	16 ~ 19
TRP-HA16	15.9	23.9	28.7	1.96	1800	3/4	3/4	—	—	—	—	14.5	21.5	27.5	3.1	
TRP-HA18	17.7	26.6	31.9	1.96	1800	3/4	3/4	—	—	—	—	14.5	21.5	27.5	3.2	
TRP-HA20	20.7	31.0	37.2	1.96	1800	3/4	3/4	—	—	—	—	15.0	22.0	28.0	3.3	

TRP-HC30	31.8	47.7	57.2	3.92	1800	1 1/4	1	—	—	—	—	—	—	—	14.5	24 ~ 26
TRP-HC40	38.6	57.2	68.6	3.92	1800	1 1/4	1	—	—	—	—	—	—	—	14.5	
TRP-HC50	52.1	78.2	93.8	3.92	1500	1 1/4	1	—	—	—	—	—	—	—	14.5	
TRP-HC65	64.8	97.3	116.7	2.94	1500	1 1/4	1	—	—	—	—	—	—	—	14.5	

Description Type	Theoretical discharge rate (L/1000min ⁻¹)	Maximum discharge pressure (MPa)	Maximum rotation speed (min ⁻¹)	Bore (Rc)		Approx. mass (kg)	Page
				IN	OUT		
TRP-B12Y	1.2	0.49	2000	1/4	1/4	1.0	30
TRP-B20Y	1.8	0.49	2000	1/4	1/4	1.1	
TRP-B27Y	2.7	0.49	2000	1/4	1/4	1.2	

TRP-BH4	4.5	0.98	2500	1/2	3/8	3.7	31
TRP-BH6	6.6	0.98	2500	1/2	1/2	3.9	
TRP-BH8	8.7	0.98	2500	3/4	1/2	4.0	
TRP-BH10	10.4	0.98	2500	3/4	3/4	4.2	
TRP-BH12	12.5	0.98	2500	3/4	3/4	4.4	

The maximum working pressures of MHG/MHA type and MHC/MHCB type are set by the output of motors to be combined. Select the maximum working pressure from the following Quick reference table:

■ MHG/MHA type, 4-pole

Type	1500 (min ⁻¹)(50Hz)					1800 (min ⁻¹)(60Hz)				
	Theoretical discharge rate(L/min)	Maximum discharge pressure (MPa)				Theoretical discharge rate(L/min)	Theoretical discharge rate(MPa)			
		200W	400W	750W	1.5kW		200W	400W	750W	1.5kW
MHG3	4.3	1.08	2.65	3.2	3.2	5.2	0.78	2.16	3.20	3.20
MHG4	6.1	0.68	1.96	3.2	3.2	7.4	0.49	1.67	2.94	3.20
MHG6	9.2	0.39	1.67	2.45	3.2	11.1	0.29	1.08	1.96	3.20
MHG8	12.3	0.29	1.27	1.77	3.2	14.8	0.20	0.88	1.67	3.20
MHG10	15.4	—	0.78	1.47	1.96	18.5	—	0.69	1.27	1.96
MHG12	18.5	—	0.69	1.27	1.96	22.3	—	0.59	1.08	1.96
MHA14	22.2	—	0.59	1.08	1.96	26.6	—	0.49	0.88	1.77
MHA16	23.9	—	0.49	0.88	1.77	28.7	—	0.39	0.69	1.37
MHA18	26.6	—	0.39	0.78	1.57	31.9	—	0.29	0.49	0.98
MHA20	31.0	—	0.29	0.69	1.37	37.2	—	0.20	0.39	0.78

■ MHC type, 4-pole

Type	1500 (min ⁻¹)(50Hz)				1800 (min ⁻¹)(60Hz)			
	Theoretical discharge rate (L/min)	Maximum discharge pressure (MPa)			Theoretical discharge rate (L/min)	Maximum discharge pressure (MPa)		
		—	1.5kW	2.2kW		—	1.5kW	2.2kW
MHC30	47.7	—	0.88	1.96	57.2	—	0.29	1.47
MHC40	57.2	—	0.29	1.47	68.6	—	—	0.88
MHC50	78.2	—	—	0.69	93.8	—	—	0.49
MHC65	97.3	—	—	0.49	116.7	—	—	—

■ MHCB type, 4-pole

Type	Bore (Rc)		1500 min ⁻¹ (50Hz)					1800 min ⁻¹ (60Hz)				
			Theoretical discharge rate (L/min)	Maximum discharge pressure (MPa)				Theoretical discharge rate (L/min)	Maximum discharge pressure (MPa)			
	Suction	Discharge		1.5kW	2.2kW	3.7kW	5.5kW		1.5kW	2.2kW	3.7kW	5.5kW
MHCB30	1¼	1	47.7	0.88	1.96	3.63	3.92	57.2	0.29	1.47	3.04	3.92
MHCB40	1¼	1	57.2	0.29	1.47	3.04	3.92	68.6	—	0.88	2.35	3.73
MHCB50	1¼	1	78.2	—	0.69	2.06	3.33	93.8	—	0.49	1.57	2.75
MHCB65	1¼	1	97.3	—	0.49	1.47	2.65	116.7	—	—	0.98	2.06

■ MHCB type, 6-pole

Type	Bore (Rc)		1000 min ⁻¹ (50Hz)				1200 min ⁻¹ (60Hz)					
			Theoretical discharge rate (L/min)	Maximum discharge pressure (MPa)			Theoretical discharge rate (L/min)	Maximum discharge pressure (MPa)				
	Suction	Discharge		0.75kW	1.5kW	2.2kW		3.7kW	0.75kW	1.5kW	2.2kW	3.7kW
MHCB30	1¼	1	31.8	0.29	1.96	3.24	3.92	38.1	0.20	1.57	2.65	3.92
MHCB40	1¼	1	38.1	0.20	1.47	2.65	3.92	45.7	—	0.98	2.06	3.73
MHCB50	1¼	1	52.1	—	0.69	1.77	3.43	62.5	—	0.29	1.27	2.84
MHCB65	1¼	1	64.8	—	0.49	1.27	2.65	77.8	—	—	0.69	2.06

TRP-A-DB

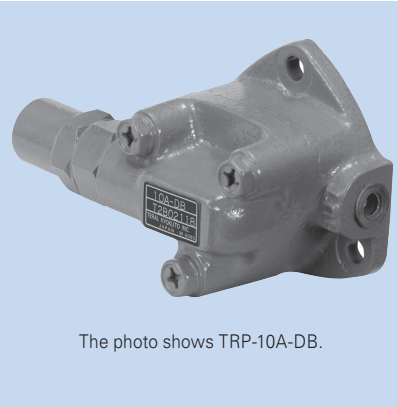

The photo shows TRP-10A-DB.

Please note that the paint color, etc. may partially differ from the photo.

Assembly drawing

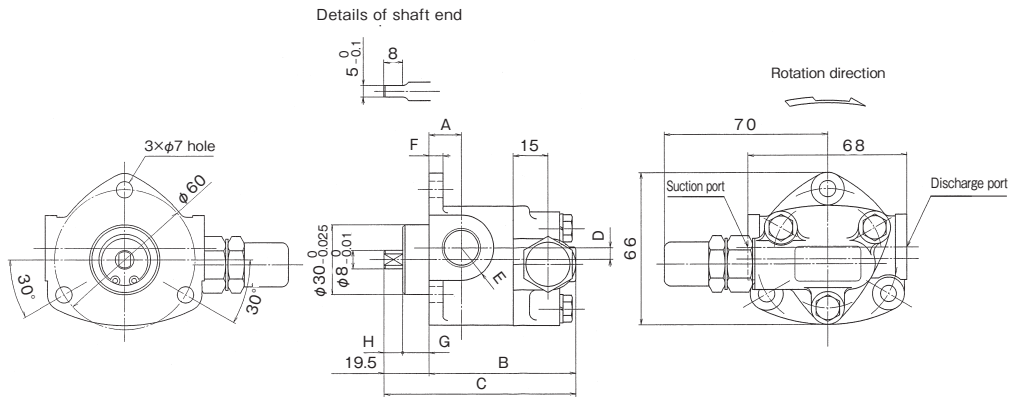

Specification and Dimensions

(Unit: mm)

Type	Theoretical discharge rate (L/1000 min ⁻¹)	Maximum discharge pressure (MPa)	Maximum rotation speed (min ⁻¹)	A	B	C Total length	D	E	F	G	H	Bore (Rc)		Approx. mass (kg)
												Suction port	Discharge port	
TRP-10A-DB	1.0	0.49	2000	10	49.5	69	1.89	10	6	11.5	8	1/8	1/8	0.8
TRP-18A-DB	1.8	0.49	2000	10	49.5	69	1.89	10	6	11.5	8	1/8	1/8	0.8
TRP-27A-DB	2.7	0.49	2000	12	57.5	77	5	14	6	11.5	8	1/4	1/4	0.9
TRP-39A-DB	4.0	0.49	2000	14	69	88.5	5	14	7	5	14.5	3/8	3/8	1.0
TRP-45A-DB	4.5	0.49	2000	14	72	91.5	5	14	7	5	14.5	3/8	3/8	1.1

TRP-A-DBT



The photo shows TRP-10A-DBT.

Please note that the paint color, etc. may partially differ from the photo.

Assembly drawing

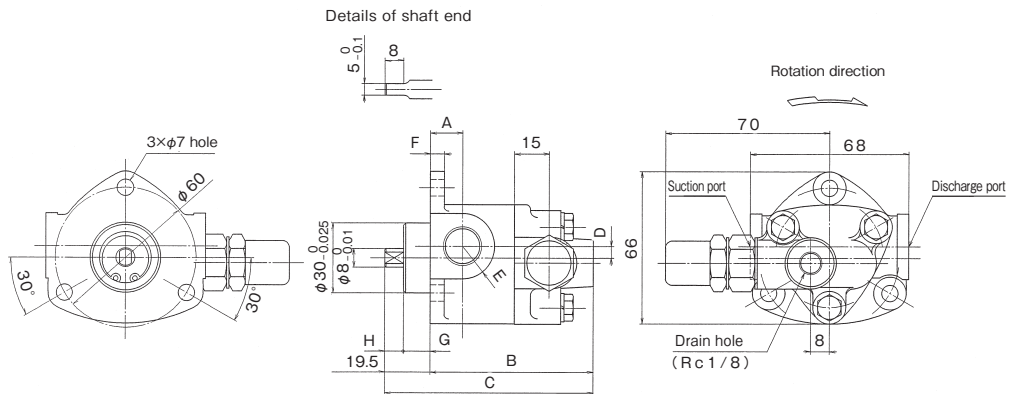

Specification and Dimensions

(Unit: mm)

Type	Theoretical discharge rate (L/1000 min ⁻¹)	Maximum discharge pressure (MPa)	Maximum rotation speed (min ⁻¹)	A	B	C Total length	D	E	F	G	H	Bore (Rc)		Approx. mass (kg)
												Suction port	Discharge port	
TRP-10A-DBT	1.0	0.49	2000	10	56	75.5	1.89	10	6	11.5	8	1/8	1/8	0.8
TRP-18A-DBT	1.8	0.49	2000	10	56	75.5	1.89	10	6	11.5	8	1/8	1/8	0.8
TRP-27A-DBT	2.7	0.49	2000	12	64	83.5	5	14	6	11.5	8	1/4	1/4	0.9
TRP-39A-DBT	4.0	0.49	2000	14	76	95.5	5	14	7	5	14.5	3/8	3/8	1.0
TRP-45A-DBT	4.5	0.49	2000	14	79	98.5	5	14	7	5	14.5	3/8	3/8	1.1

Applications

Various machine tools, industrial machines, etc.

Description of types

TRP - M A J - - - - (L)---Standard
 ① ② ③ ④ ⑤ ⑥ ⑦ ⑧ (R)

- ① Pump with motor
- ② Model (A Type)
- ③ Discharge rate (10, 18, 27, 39, 45)
- ④ Coupling type
- ⑤ Relief valve (Blank: without DB, DB, DBT)
- ⑥ Motor output (0.075kW (75), 0.1 kW (100), 100W (1), 0.2 kW/200W (2))
- ⑦ Motor specification (W, TK, SP, EK)
- ⑧ Rotation direction

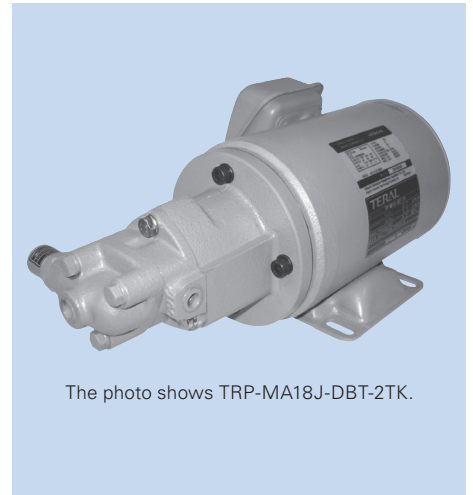

The photo shows TRP-MA18J-DBT-2TK.

Please note that the paint color, etc. may partially differ from the photo.

MA type pump (single)

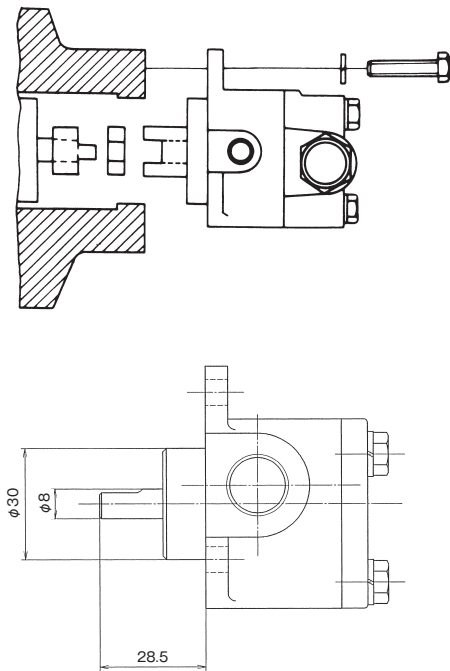

Specification table

Type	Theoretical discharge rate (L/min)		Maximum discharge pressure (MPa)	
	1500min ⁻¹	1800min ⁻¹	1500min ⁻¹	1800min ⁻¹
TRP-MA10J-75W	1.6	1.9	0.49	0.49
TRP-MA18J-75W	2.7	3.2	0.39	0.29
TRP-MA27J-75W	4.1	4.9	0.20	0.10
TRP-MA10J-100W	1.6	1.9	0.49	0.49
TRP-MA18J-100W	2.7	3.2	0.49	0.49
TRP-MA27J-100W	4.1	4.9	0.29	0.20
TRP-MA39J-100W	6.0	7.2	0.20	0.10
TRP-MA10J-2TK	1.6	1.9	0.49	0.49
TRP-MA18J-2TK	2.7	3.2	0.49	0.49
TRP-MA27J-2TK	4.1	4.9	0.49	0.49
TRP-MA39J-2TK	6.0	7.2	0.49	0.49
TRP-MA45J-2TK	6.8	8.2	0.49	0.49
TRP-MA10J-1SP	1.6	1.9	0.49	0.49
TRP-MA18J-1SP	2.7	3.2	0.49	0.49
TRP-MA27J-1SP	4.1	4.9	0.29	0.20
TRP-MA39J-1SP	6.0	7.2	0.20	0.10
TRP-MA10J-2EK	1.6	1.9	0.49	0.49
TRP-MA18J-2EK	2.7	3.2	0.49	0.49
TRP-MA27J-2EK	4.1	4.9	0.49	0.49
TRP-MA39J-2EK	6.0	7.2	0.49	0.49
TRP-MA45J-2EK	6.8	8.2	0.49	0.49

TRP-MAJ-75W

Assembly drawing

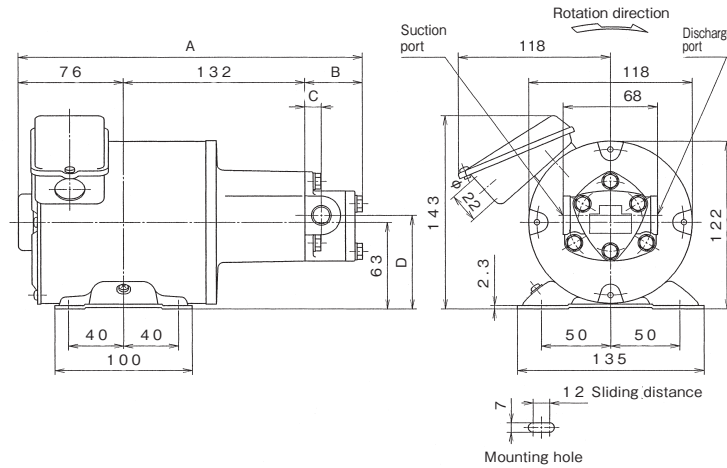

Motor specification (3-phase induction motor, totally-enclosed self-cooled indoor type)

Type	Output	Pole number	Voltage (V)	Frequency (Hz)	Rating	Thermal class
TP-4512T	0.075kW	4P	200	50	Continuous	E
			200/220	60		

Specification and dimensions

(Unit: mm)

Type	Theoretical discharge rate (L/min)		Maximum discharge pressure (MPa)		A	B	C	D	Bore (Rc)		Approx. mass (kg)
	1500min ⁻¹	1800min ⁻¹	1500min ⁻¹	1800min ⁻¹					Suction port	Discharge port	
TRP-MA10J-75W	1.6	1.9	0.49	0.49	242	34	10	64.89	1/8	1/8	6.5
TRP-MA18J-75W	2.7	3.2	0.39	0.29	242	34	10	64.89	1/8	1/8	6.5
TRP-MA27J-75W	4.1	4.9	0.20	0.10	250	42	12	68	1/4	1/4	6.5

*The dimensions A and B in the table are 15.5mm longer for DB, and 22mm longer for DBT. The drain hole size of DBT is Rc 1/8.

TRP-MAJ-100W

Assembly drawing

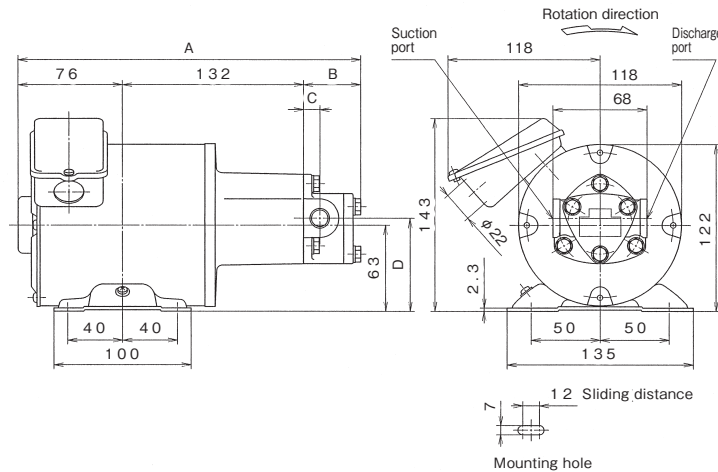

Motor specification (3-phase induction motor, totally-enclosed self-cooled indoor type)

Type	Output	Pole number	Voltage (V)	Frequency (Hz)	Rating	Thermal class
TP-4512T	0.1kW	4P	200	50	Continuous	E
			200/220	60		

Specification and dimensions

(Unit: mm)

Type	Theoretical discharge rate (L/min)		Maximum discharge pressure (MPa)		A	B	C	D	Bore (Rc)		Approx. mass (kg)
	1500min ⁻¹	1800min ⁻¹	1500min ⁻¹	1800min ⁻¹					Suction port	Discharge port	
TRP-MA10J-100W	1.6	1.9	0.49	0.49	242	34	10	64.89	1/8	1/8	6.5
TRP-MA18J-100W	2.7	3.2	0.49	0.49	242	34	10	64.89	1/8	1/8	6.5
TRP-MA27J-100W	4.1	4.9	0.29	0.20	250	42	12	68	1/4	1/4	6.5
TRP-MA39J-100W	6.0	7.2	0.20	0.10	262.5	54.5	14	68	3/8	3/8	6.5

*The dimensions A and B in the table are 15.5mm longer for DB, and 22mm longer for DBT. The drain hole size of DBT is Rc 1/8.

TRP-MAJ-2TK

Assembly drawing

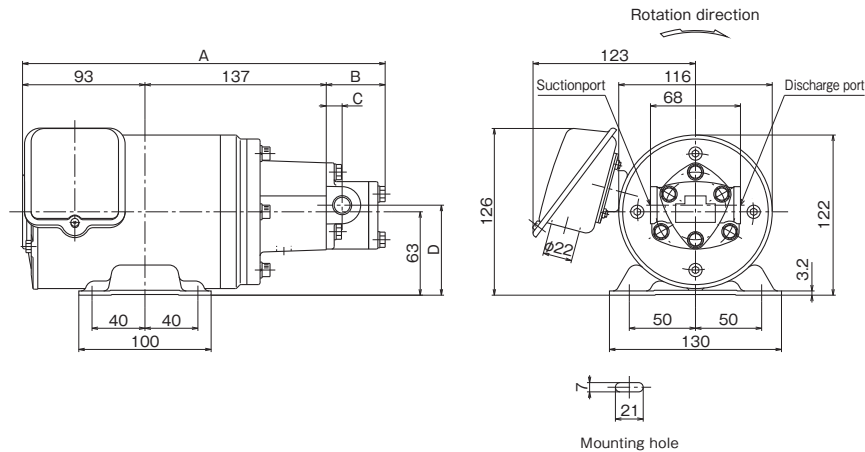

Motor specification (3-phase induction motor, totally-enclosed indoor type)

Type	Output	Pole number	Voltage (V)	Frequency (Hz)	Rating	Thermal class
TO-K	0.2kW	4P	200	50	S1	E
			200/220	60		

Specification and Dimensions

(Unit: mm)

Type	Theoretical discharge rate (L/min)		Maximum discharge pressure (MPa)		A	B	C	D	Bore (Rc)		Approx. mass (kg)
	1500min ⁻¹	1800min ⁻¹	1500min ⁻¹	1800min ⁻¹					Suction port	Discharge port	
TRP-MA10J-2TK	1.6	1.9	0.49	0.49	264	34	10	65	1/8	1/8	9.5
TRP-MA18J-2TK	2.7	3.2	0.49	0.49	264	34	10	65	1/8	1/8	9.5
TRP-MA27J-2TK	4.1	4.9	0.49	0.49	272	42	12	68	1/4	1/4	9.5
TRP-MA39J-2TK	6.0	7.2	0.49	0.49	285	55	14	68	3/8	3/8	9.5
TRP-MA45J-2TK	6.8	8.2	0.49	0.49	288	58	14	68	3/8	3/8	9.5

*The dimensions A and B in the table are 15.5mm longer for DB, and 22mm longer for DBT. The drain port of DBT is Rc 1/8.

TRP-MAJ-2EK

Assembly drawing

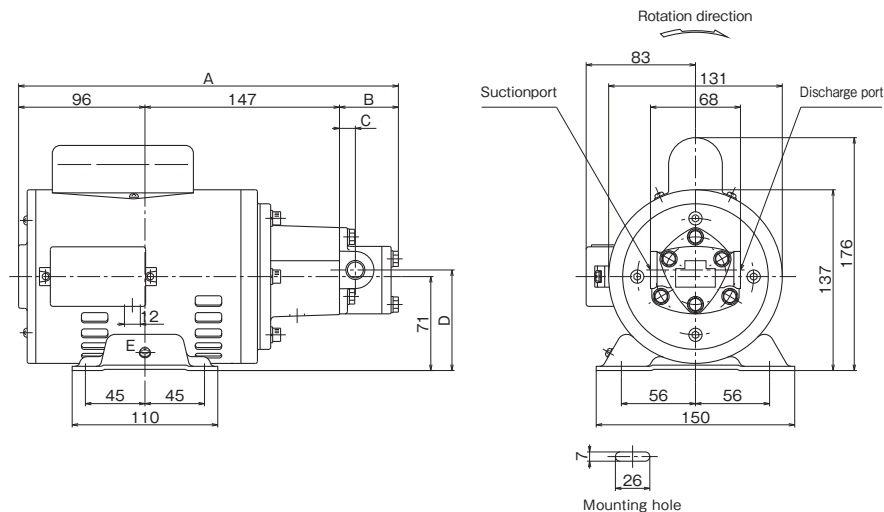

Motor specification (Capacitor start single-phase induction motor, drip-proof type)

Type	Output	Pole number	Voltage (V)	Frequency (Hz)	Rating	Thermal class
EFOU-KR	200W	4P	100	50	S1	E
			100	60		

Specification and Dimensions

(Unit: mm)

Type	Theoretical discharge rate (L/min)		Maximum discharge pressure (MPa)		A	B	C	D	Bore (Rc)		Approx. mass (kg)
	1500min ⁻¹	1800min ⁻¹	1500min ⁻¹	1800min ⁻¹					Suction port	Discharge port	
TRP-MA10J-2EK	1.6	1.9	0.49	0.49	277	34	10	73	1/8	1/8	11.0
TRP-MA18J-2EK	2.7	3.2	0.49	0.49	277	34	10	73	1/8	1/8	11.0
TRP-MA27J-2EK	4.1	4.9	0.49	0.49	285	42	12	76	1/4	1/4	11.0
TRP-MA39J-2EK	6.0	7.2	0.49	0.49	298	55	14	76	3/8	3/8	11.0
TRP-MA45J-2EK	6.8	8.2	0.49	0.49	301	58	14	76	3/8	3/8	11.0

*The dimensions A and B in the table are 15.5mm longer for DB, and 22mm longer for DBT. The drain port of DBT is Rc 1/8.

■ Component drawing

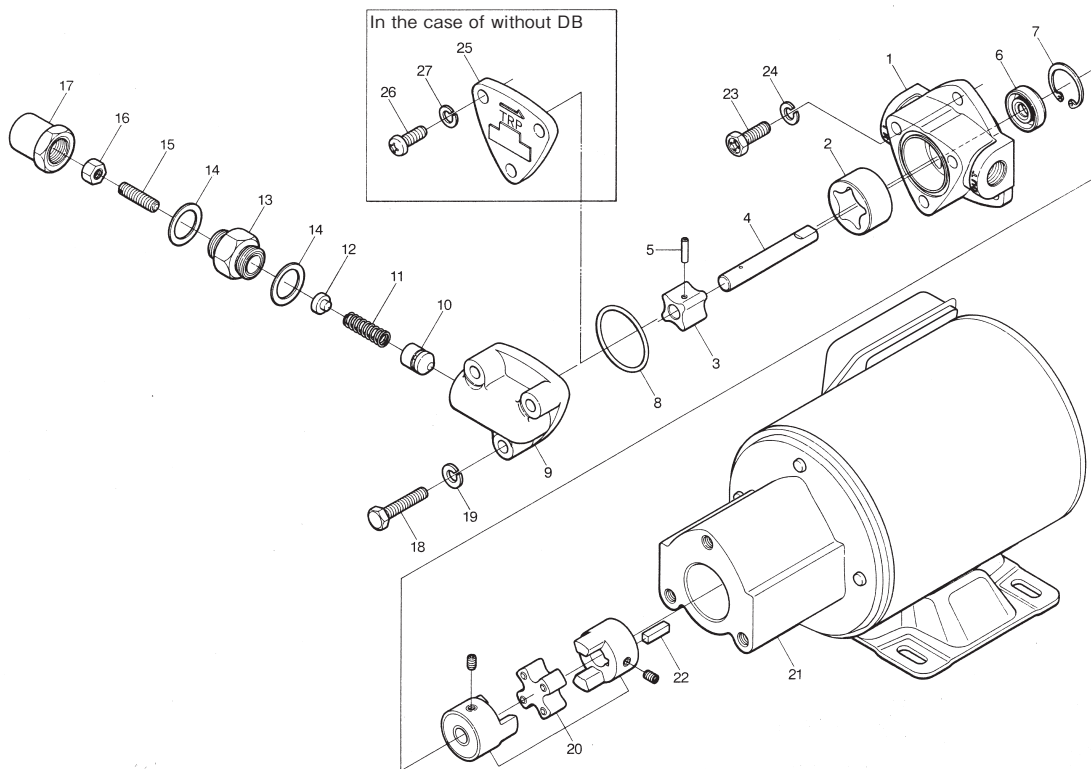

■ Parts list

No.	Part name
1	Casing
2	Outer rotor
3	Inner rotor
4	Shaft
5	Dowel pin
6	Oil seal S8227
7	Retaining ring
8	O-ring 2×32×36
9	Valve case
10	Valve element
11	Spring
12	Spring retainer
13	Connector
14	Sheet packing

No.	Part name
15	Adjusting screw
16	Hexagon nut
17	Cap
18	Hexagon head bolt
19	Spring washer
20	Coupling
21	Motor
22	Key
23	Hexagon head bolt
24	Spring washer
25	Casing cover
26	Hexagon head bolt
27	Spring washer

Features

Coolant specification (CL) and thermal specification (VT) are available.

Description of types

TRP - H^GA - (L) ··· Standard
(R)

① ② ③ ④ ⑤ ⑥

- ① Model (H type)
- ② Type (G, A)
- ③ Discharge rate (3 - 20 (G:3 - 12, A:14 - 20))
- ④ Installation method (F, L)
- ⑤ Relief valve (Blank: without DB, DB, DBT)
- ⑥ Rotation direction



The photo shows TRP-HG6L-DB.

Please note that the paint color, etc. may partially differ from the photo.

Performance curve

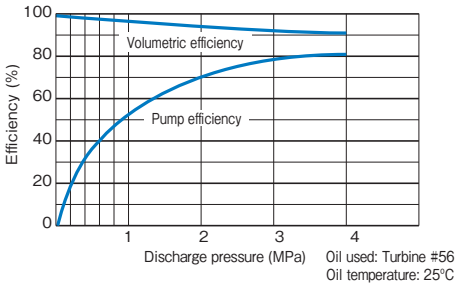

Oil temperature and volumetric efficiency

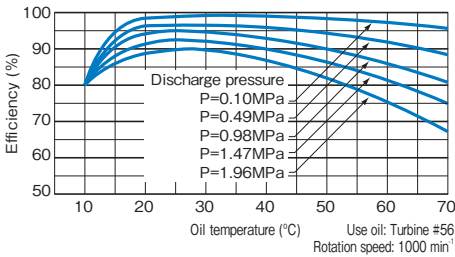

Shaft power (kW) per 1000 min⁻¹

Type	0.29MPa	0.49MPa	0.98MPa	1.47MPa	1.96MPa	2.94MPa
TRP-HG3	0.060	0.062	0.083	0.115	0.138	0.194
TRP-HG4	0.079	0.083	0.111	0.153	0.185	0.259
TRP-HG6	0.120	0.124	0.166	0.230	0.277	0.389
TRP-HG8	0.159	0.166	0.222	0.307	0.370	0.519
TRP-HG10	0.199	0.208	0.277	0.384	0.462	0.649
TRP-HG12	0.240	0.249	0.333	0.461	0.555	0.779
TRP-HA14	0.279	0.291	0.388	0.538	0.648	0.909
TRP-HA16	0.319	0.333	0.444	0.615	0.740	1.038
TRP-HA18	0.360	0.375	0.499	0.692	0.833	1.168
TRP-HA20	0.399	0.416	0.555	0.769	0.925	1.461

Component drawing

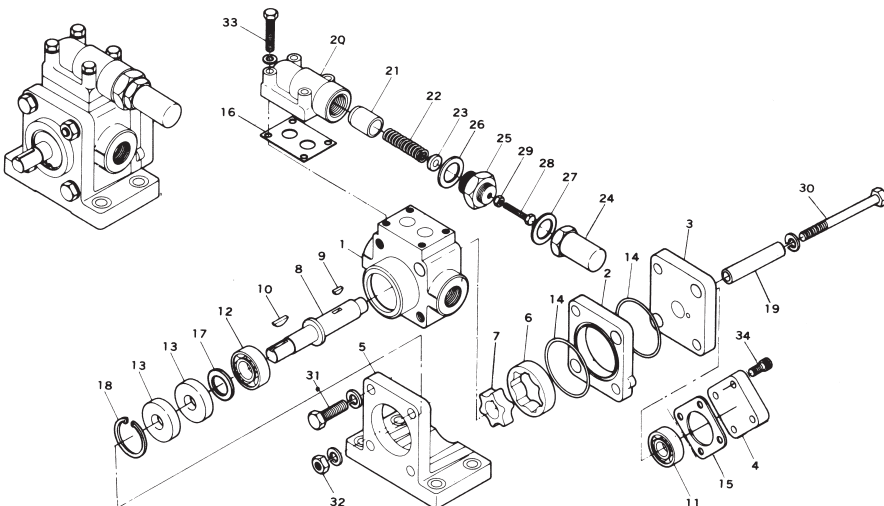

Parts list

No.	Part name	No.	Part name
1	Casing	18	Retaining ring
2	Rotor housing	19	Dowel pin
3	Bearing case	20	Valve case
4	Bearing cover	21	Valve element
5	Mounting legs	22	Spring
6	Outer rotor	23	Spring retainer
7	Inner rotor	24	Cap
8	Shaft	25	Connector
9	Key	26	Sheet packing
10	Key	27	Sheet packing
11	Bearing 6301	28	Adjusting screw
12	Bearing 6202	29	Hexagon nut
13	Oil seal S15357	30	Hexagon head bolt
14	O-ring S56	31	Hexagon head bolt
15	Sheet packing	32	Hexagon nut
16	Sheet packing	33	Hexagon head bolt
17	Collar	34	Hexagon head bolt

TRP-HG



Please note that the paint color, etc. may partially differ from the photo.

Assembly drawing

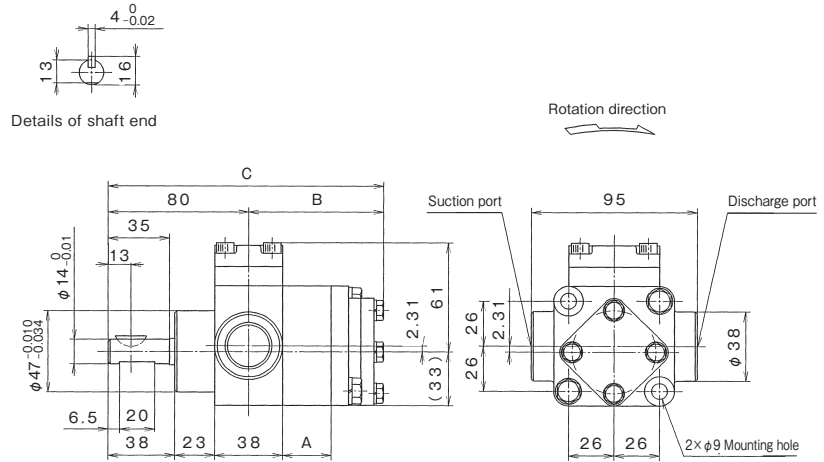

Specification and Dimensions

(Unit: mm)

Type	Theoretical discharge rate(L/1000 min ⁻¹)	Maximum discharge pressure(MPa)	Maximum rotation speed(min ⁻¹)	A	B	C Total length	Bore (Rc)		Approx. mass(kg)
							Suction port	Discharge port	
TRP-HG3	2.8	3.2	2000	7	58	138	1/2	1/2	2.5
TRP-HG4	4.1	3.2	2000	10	61	141	1/2	1/2	2.6
TRP-HG6	6.1	3.2	2000	15	66	146	1/2	1/2	2.8
TRP-HG8	8.2	3.2	2000	20	71	151	1/2	1/2	2.9
TRP-HG10	10.3	1.96	2000	25	76	156	3/4	3/4	3.0
TRP-HG12	12.3	1.96	2000	30	81	161	3/4	3/4	3.2

*When a pressure exceeding the maximum discharge pressure is required, please contact us accordingly.

TRP-HA

Assembly drawing

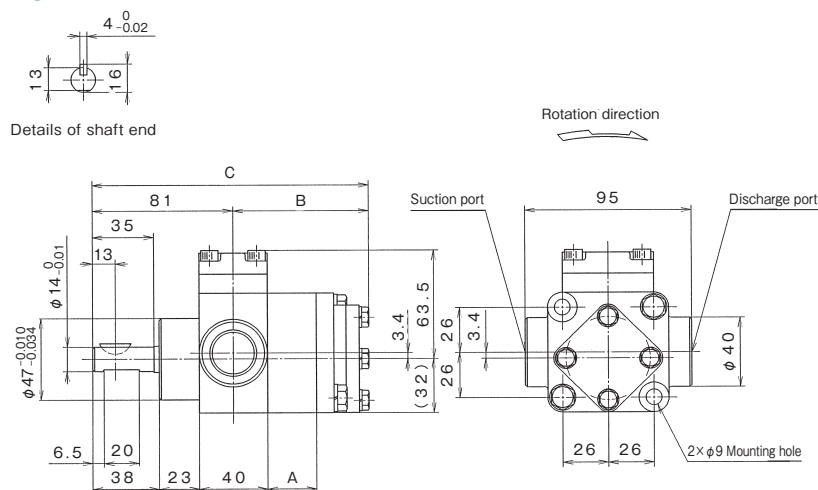

Specification and Dimensions

(Unit: mm)

Type	Theoretical discharge rate(L/1000 min ⁻¹)	Maximum discharge pressure(MPa)	Maximum rotation speed(min ⁻¹)	A	B	C Total length	Bore (Rc)		Approx. mass(kg)
							Suction port	Discharge port	
TRP-HA14	14.8	1.96	2000	25	77	158	3/4	3/4	3.0
TRP-HA16	15.9	1.96	1800	27	79	160	3/4	3/4	3.1
TRP-HA18	17.7	1.96	1800	30	82	163	3/4	3/4	3.2
TRP-HA20	20.7	1.96	1800	35	87	168	3/4	3/4	3.3

TRP-HGL-DB

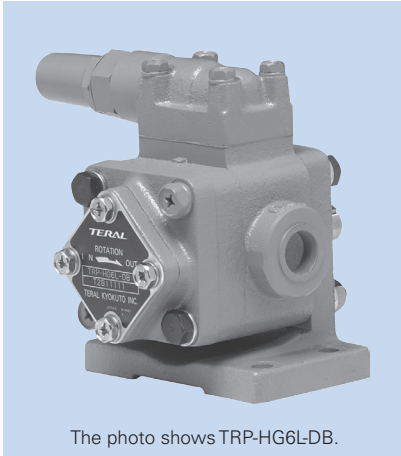

The photo shows TRP-HG6L-DB.

Please note that the paint color, etc. may partially differ from the photo.

Assembly drawing

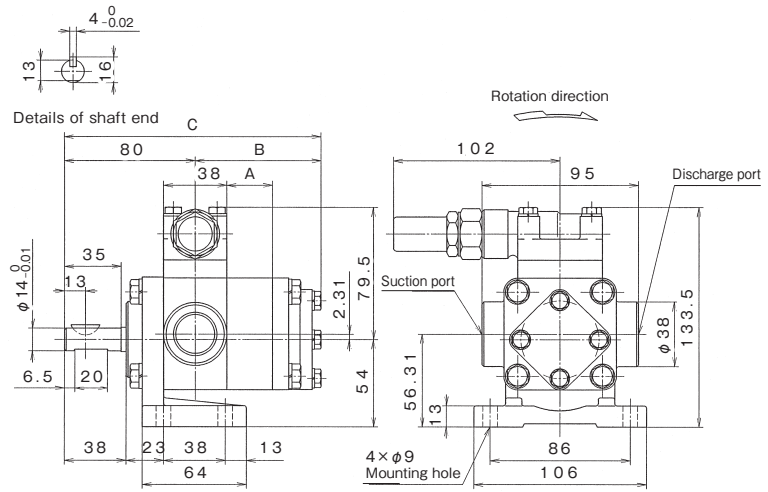

Specification and Dimensions

(Unit: mm)

Type	Theoretical discharge rate(L/1000 min ⁻¹)	Maximum discharge pressure(MPa)	Maximum rotation speed(min ⁻¹)	A	B	C Total length	Bore (Rc)		Approx. mass(kg)
							Suction port	Discharge port	
TRP-HG3L-DB	2.8	3.2	2000	7	58	138	1/2	1/2	3.8
TRP-HG4L-DB	4.1	3.2	2000	10	61	141	1/2	1/2	3.9
TRP-HG6L-DB	6.1	3.2	2000	15	66	146	1/2	1/2	4.0
TRP-HG8L-DB	8.2	3.2	2000	20	71	151	1/2	1/2	4.2
TRP-HG10L-DB	10.3	1.96	2000	25	76	156	3/4	3/4	4.3
TRP-HG12L-DB	12.3	1.96	2000	30	81	161	3/4	3/4	4.5

*When a pressure exceeding the maximum discharge pressure is required, please contact us accordingly.

TRP-HAL-DB

Assembly drawing

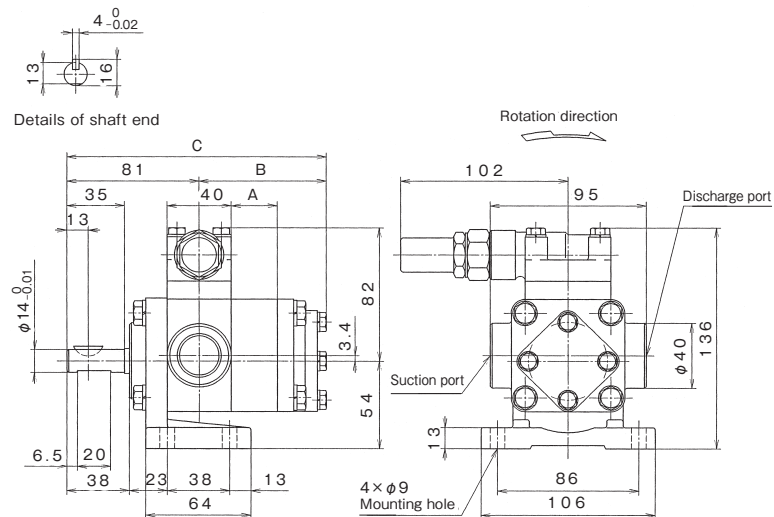

Specification and Dimensions

(Unit: mm)

Type	Theoretical discharge rate(L/1000 min ⁻¹)	Maximum discharge pressure(MPa)	Maximum rotation speed(min ⁻¹)	A	B	C Total length	Bore (Rc)		Approx. mass(kg)
							Suction port	Discharge port	
TRP-HA14L-DB	14.8	1.96	2000	25	77	158	3/4	3/4	4.3
TRP-HA16L-DB	15.9	1.96	1800	27	79	160	3/4	3/4	4.4
TRP-HA18L-DB	17.7	1.96	1800	30	82	163	3/4	3/4	4.5
TRP-HA20L-DB	20.7	1.96	1800	35	87	168	3/4	3/4	4.6

TRP-HGF-DBT

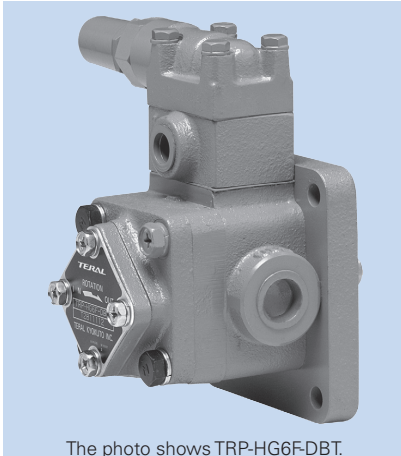

The photo shows TRP-HGF-DBT.

Please note that the paint color, etc. may partially differ from the photo.

Assembly drawing

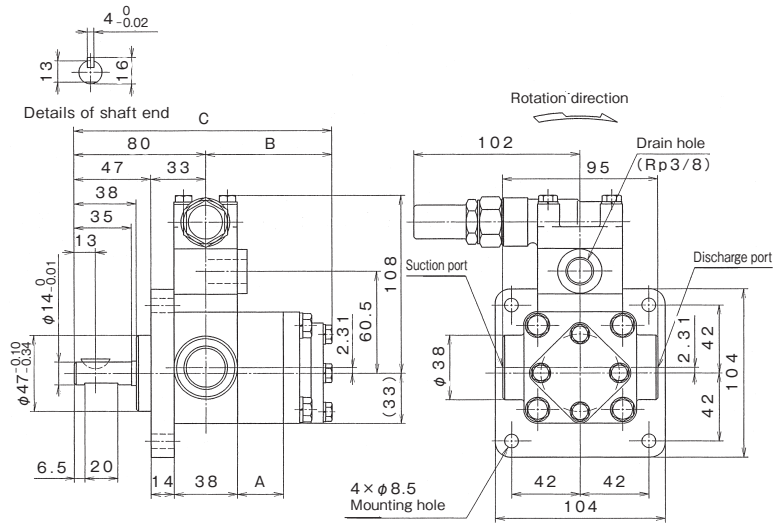

Specification and Dimensions

(Unit: mm)

Type	Theoretical discharge rate(L/1000 min ⁻¹)	Maximum discharge pressure(MPa)	Maximum rotation speed(min ⁻¹)	A	B	C Total length	Bore (Rc)		Approx. mass(kg)
							Suction port	Discharge port	
TRP-HG3F-DBT	2.8	3.2	2000	7	58	138	1/2	1/2	4.2
TRP-HG4F-DBT	4.1	3.2	2000	10	61	141	1/2	1/2	4.3
TRP-HG6F-DBT	6.1	3.2	2000	15	66	146	1/2	1/2	4.5
TRP-HG8F-DBT	8.2	3.2	2000	20	71	151	1/2	1/2	4.7
TRP-HG10F-DBT	10.3	1.96	2000	25	76	156	3/4	3/4	4.8
TRP-HG12F-DBT	12.3	1.96	2000	30	81	161	3/4	3/4	4.9

*When a pressure exceeding the maximum discharge pressure is required, please contact us accordingly.

TRP-HAF-DBT

Assembly drawing

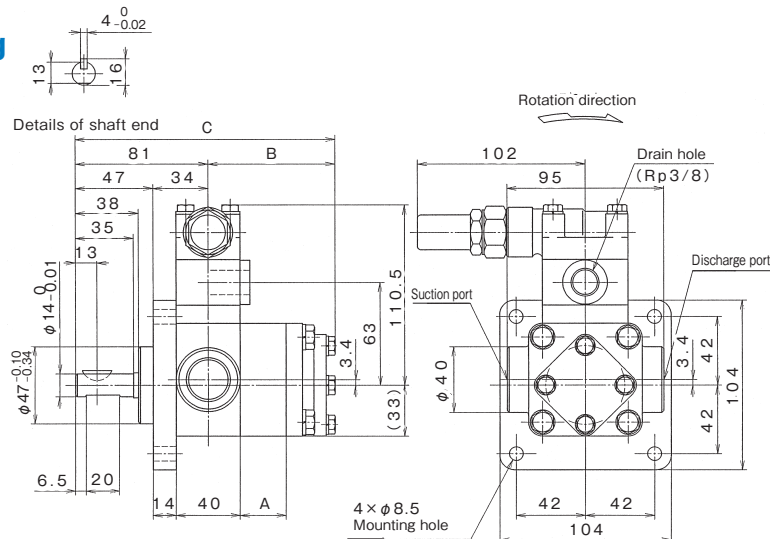

Specification and Dimensions

(Unit: mm)

Type	Theoretical discharge rate(L/1000 min ⁻¹)	Maximum discharge pressure(MPa)	Maximum rotation speed(min ⁻¹)	A	B	C Total length	Bore (Rc)	Approx. mass(kg)
TRP-HA14F-DBT	14.8	1.96	2000	25	77	158	3/4	4.7
TRP-HA16F-DBT	15.9	1.96	1800	27	79	160	3/4	4.8
TRP-HA18F-DBT	17.7	1.96	1800	30	82	163	3/4	4.9
TRP-HA20F-DBT	20.7	1.96	1800	35	87	168	3/4	5.0

Features

- ① In the case of safety explosion-proof and pressure-proof explosion-proof electric motors, the pump is equipped with a base.
- ② Coolant specification (CL) and thermal specification (VT) are available.
(For an assembly drawing, please inquire with us separately.)

Description of types



- ① Pump with motor
- ② Model (H type)
- ③ Type (G, A)
- ④ Structure (Blank: motor-integrated, B: with base)
- ⑤ Discharge rate (3 – 20 (G: 3 – 12, A: 14 – 20))
- ⑥ Relief valve (Blank: without DB, DB, DBT)
- ⑦ Motor output
 0.2kW/200W (2), 0.4kW/400W (4)
 0.75kW/750W (75), 1.5kW (15)
- ⑧ Motor specification (TK, EK, FK, SC)
- ⑨ Rotation direction
- ⑩ Motor efficiency
 Blank: Standard efficiency (equivalent to IE1)
 -e: Top Runner efficiency (equivalent to IE3)



The photo shows TRP-MHG3-4EK.

Please note that the paint color, etc. may partially differ from the photo.

Example of relief valve assembly

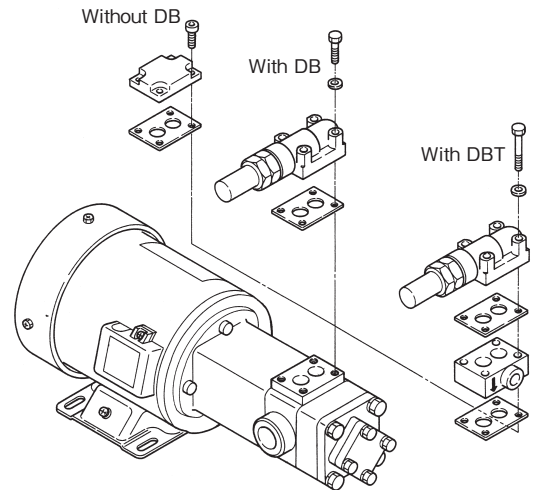

Component drawing

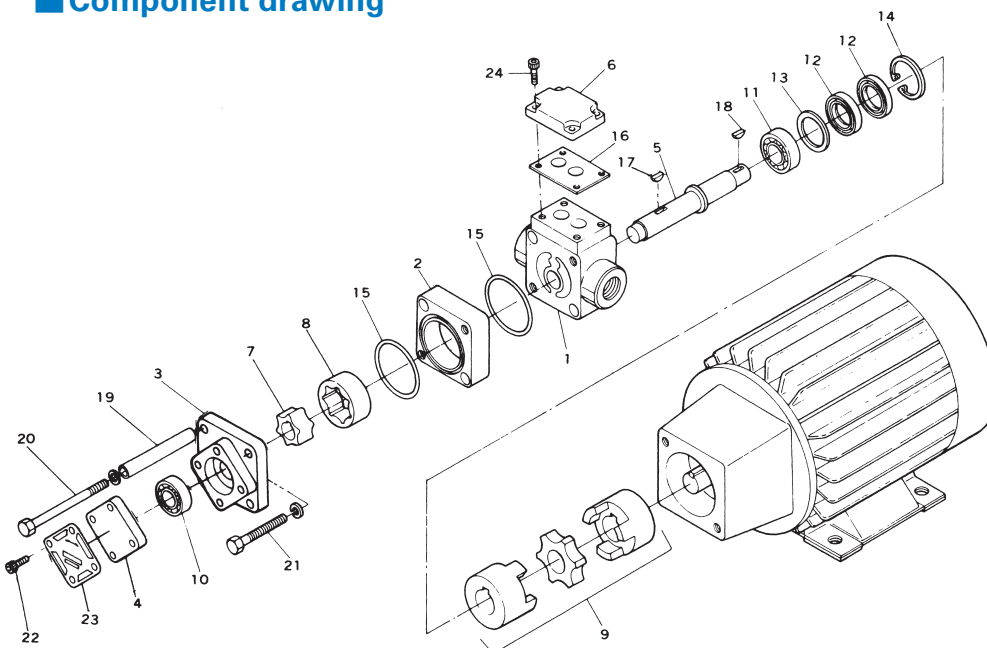

Parts list

No.	Part Name
1	Casing
2	Rotor housing
3	Bearing case
4	Bearing cover
5	Shaft
6	Head cover
7	Inner rotor
8	Outer rotor
9	Coupling
10	Bearing 6301
11	Bearing 6202
12	Oil seal S15357
13	Collar
14	Retaining ring
15	O-ring S56
16	Sheet packing
17	Key
18	Key
19	Dowel pin
20	Hexagon head bolt
21	Hexagon head bolt
22	Hexagon head bolt
23	Nameplate
24	Hexagon socket head cap screw

Specification table

Type	Theoretical discharge rate (L/min)		Maximum discharge pressure (MPa)		Type	Theoretical discharge rate (L/min)		Maximum discharge pressure (MPa)	
	1500min ⁻¹	1800min ⁻¹	1500min ⁻¹	1800min ⁻¹		1500min ⁻¹	1800min ⁻¹	1500min ⁻¹	1800min ⁻¹
TRP-MHG 3-2TK	4.3	5.2	1.08	0.78	TRP-MHG 3-75FK-e	4.3	5.2	3.2	3.2
TRP-MHG 4-2TK	6.1	7.4	0.69	0.49	TRP-MHG 4-75FK-e	6.1	7.4	3.2	2.94
TRP-MHG 6-2TK	9.2	11.1	0.39	0.29	TRP-MHG 6-75FK-e	9.2	11.1	2.45	1.96
TRP-MHG 8-2TK	12.3	14.8	0.29	0.20	TRP-MHG 8-75FK-e	12.3	14.8	1.77	1.67
TRP-MHG 3-2EK	4.3	5.2	1.08	0.78	TRP-MHG10-75FK-e	15.4	18.5	1.47	1.27
TRP-MHG 4-2EK	6.1	7.4	0.69	0.49	TRP-MHG12-75FK-e	18.5	22.3	1.27	1.08
TRP-MHG 6-2EK	9.2	11.1	0.39	0.29	TRP-MHA14-75FK-e	22.2	26.6	1.08	0.88
TRP-MHG 8-2EK	12.3	14.8	0.29	0.20	TRP-MHA16-75FK-e	23.9	28.7	0.88	0.69
TRP-MHG 3-4FK	4.3	5.2	2.65	2.16	TRP-MHA18-75FK-e	26.6	31.9	0.78	0.49
TRP-MHG 4-4FK	6.1	7.4	1.96	1.67	TRP-MHA20-75FK-e	31.0	37.2	0.69	0.39
TRP-MHG 6-4FK	9.2	11.1	1.67	1.08	TRP-MHG 3-75SC	4.3	5.2	3.2	3.2
TRP-MHG 8-4FK	12.3	14.8	1.27	0.88	TRP-MHG 4-75SC	6.1	7.4	3.2	2.94
TRP-MHG10-4FK	15.4	18.5	0.78	0.69	TRP-MHG 6-75SC	9.2	11.1	2.45	1.96
TRP-MHG12-4FK	18.5	22.3	0.69	0.59	TRP-MHG 8-75SC	12.3	14.8	1.77	1.67
TRP-MHA14-4FK	22.2	26.6	0.59	0.49	TRP-MHG10-75SC	15.4	18.5	1.47	1.27
TRP-MHA16-4FK	23.9	28.7	0.49	0.39	TRP-MHG12-75SC	18.5	22.3	1.27	1.08
TRP-MHA18-4FK	26.6	31.9	0.39	0.29	TRP-MHA14-75SC	22.2	26.6	1.08	0.88
TRP-MHA20-4FK	31.0	37.2	0.29	0.20	TRP-MHA16-75SC	23.9	28.7	0.88	0.69
TRP-MHG 3-4EK	4.3	5.2	2.65	2.16	TRP-MHA18-75SC	26.6	31.9	0.78	0.49
TRP-MHG 4-4EK	6.1	7.4	1.96	1.67	TRP-MHA20-75SC	31.0	37.2	0.69	0.39
TRP-MHG 6-4EK	9.2	11.1	1.67	1.08	TRP-MHG 3-15FK-e	4.3	5.2	3.2	3.2
TRP-MHG 8-4EK	12.3	14.8	1.27	0.88	TRP-MHG 4-15FK-e	6.1	7.4	3.2	3.2
TRP-MHG10-4EK	15.4	18.5	0.78	0.69	TRP-MHG 6-15FK-e	9.2	11.1	3.2	3.2
TRP-MHG12-4EK	18.5	22.3	0.69	0.59	TRP-MHG 8-15FK-e	12.3	14.8	3.2	3.2
TRP-MHA14-4EK	22.2	26.6	0.59	0.49	TRP-MHG10-15FK-e	15.4	18.5	1.96	1.96
TRP-MHA16-4EK	23.9	28.7	0.49	0.39	TRP-MHG12-15FK-e	18.5	22.3	1.96	1.96
TRP-MHA18-4EK	26.6	31.9	0.39	0.29	TRP-MHA14-15FK-e	22.2	26.6	1.96	1.77
TRP-MHA20-4EK	31.0	37.2	0.29	0.20	TRP-MHA16-15FK-e	23.9	28.7	1.77	1.37
					TRP-MHA18-15FK-e	26.6	31.9	1.57	0.98
					TRP-MHA20-15FK-e	31.0	37.2	1.37	0.78

* When a pressure exceeding the maximum discharge pressure is required, please contact us accordingly.

Motor output and motor specification

2TK	Totally-enclosed indoor type 3-phase induction motor	0.2kW, 4P, 200V/50 and 60Hz, 220V/60Hz, thermal class E, Continuous rating
2EK	Capacitor start single-phase induction motor	200W, 4P, 100V/50 and 60 Hz, thermal class E, continuous rating
4FK	Totally-enclosed fan-cooled indoor type 3-phase induction motor	0.4kW, 4P, 200V/50 and 60 Hz, 220V/60Hz, thermal class E, continuous rating
4EK	Capacitor start single-phase induction motor	400W, 4P, 100 and 200 V/50 and 60 Hz, thermal class E, continuous rating
75FK	Totally-enclosed fan-cooled indoor type 3-phase induction motor	075kW, 4P, 200V/50 and 60 Hz, 220V/60Hz, thermal class E, continuous rating
75SC	Capacitor start capacitor run single-phase induction motor	750W, 4P, 100 and 200V/50 and 60Hz, thermal class E, continuous rating
15FK	Totally-enclosed fan-cooled indoor type 3-phase induction motor	1.5kW, 4P, 200V/50 and 60 Hz, 220V/60Hz, thermal class E, continuous rating

For special voltage, tropical treatment and other special specifications, please contact us accordingly.

TRP-MHG/MHA



The photo shows TRP-MHG3-DB-4FK.

Please note that the paint color, etc. may partially differ from the photo.

Assembly drawing

● TRP-MH^g-DB

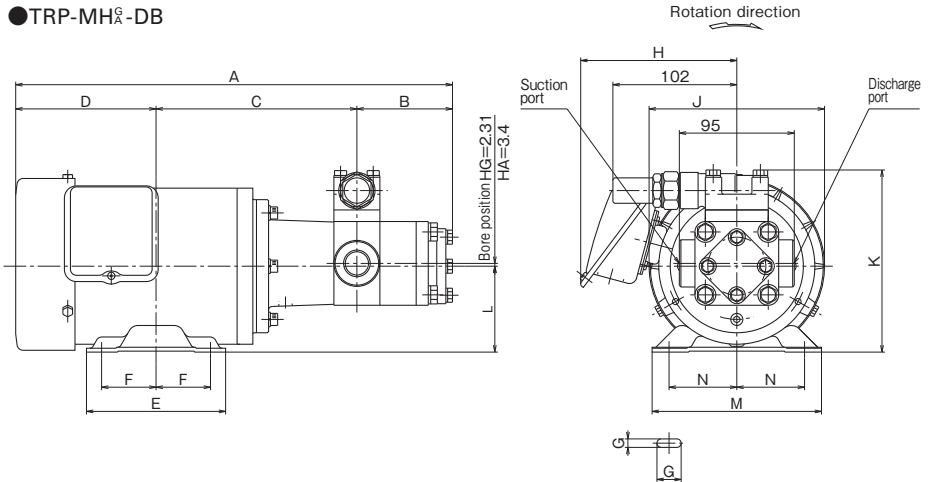

Dimensions

(Unit: mm)

Type	A	B	C	D	E	F	G	H	J	K	L	M	N	Bore (Rc) Suction, Discharge
TRP-MHG 3-2TK	311	58	160	93	100	40	7x21	123	116	124/142.5/171	63	130	50	1/2
TRP-MHG 4-2TK	314	61	160	93	100	40	7x21	123	116	124/142.5/171	63	130	50	1/2
TRP-MHG 6-2TK	319	66	160	93	100	40	7x21	123	116	124/142.5/171	63	130	50	1/2
TRP-MHG 8-2TK	324	71	160	93	100	40	7x21	123	116	124/142.5/171	63	130	50	1/2
TRP-MHG 3-4FK	340	58	166	116	115	45	7x20	129	145	132/150.5/179	71	140	56	1/2
TRP-MHG 4-4FK	343	61	166	116	115	45	7x20	129	145	132/150.5/179	71	140	56	1/2
TRP-MHG 6-4FK	348	66	166	116	115	45	7x20	129	145	132/150.5/179	71	140	56	1/2
TRP-MHG 8-4FK	353	71	166	116	115	45	7x20	129	145	132/150.5/179	71	140	56	1/2
TRP-MHG10-4FK	358	76	166	116	115	45	7x20	129	145	132/150.5/179	71	140	56	3/4
TRP-MHG12-4FK	363	81	166	116	115	45	7x20	129	145	132/150.5/179	71	140	56	3/4
TRP-MHA14-4FK	360	77	167	116	115	45	7x20	129	145	134.5/153/181.5	71	140	56	3/4
TRP-MHA16-4FK	362	79	167	116	115	45	7x20	129	145	134.5/153/181.5	71	140	56	3/4
TRP-MHA18-4FK	365	82	167	116	115	45	7x20	129	145	134.5/153/181.5	71	140	56	3/4
TRP-MHA20-4FK	370	87	167	116	115	45	7x20	129	145	134.5/153/181.5	71	140	56	3/4
TRP-MHG 3-75FK-e	372	58	173	141	125	50	10x25	136	163	141/159.5/188	80	160	62.5	1/2
TRP-MHG 4-75FK-e	375	61	173	141	125	50	10x25	136	163	141/159.5/188	80	160	62.5	1/2
TRP-MHG 6-75FK-e	380	66	173	141	125	50	10x25	136	163	141/159.5/188	80	160	62.5	1/2
TRP-MHG 8-75FK-e	385	71	173	141	125	50	10x25	136	163	141/159.5/188	80	160	62.5	1/2
TRP-MHG10-75FK-e	390	76	173	141	125	50	10x25	136	163	141/159.5/188	80	160	62.5	3/4
TRP-MHG12-75FK-e	395	81	173	141	125	50	10x25	136	163	141/159.5/188	80	160	62.5	3/4
TRP-MHA14-75FK-e	392	77	174	141	125	50	10x25	136	163	143.5/162/190.5	80	160	62.5	3/4
TRP-MHA16-75FK-e	394	79	174	141	125	50	10x25	136	163	143.5/162/190.5	80	160	62.5	3/4
TRP-MHA18-75FK-e	397	82	174	141	125	50	10x25	136	163	143.5/162/190.5	80	160	62.5	3/4
TRP-MHA20-75FK-e	402	87	174	141	125	50	10x25	136	163	143.5/162/190.5	80	160	62.5	3/4
TRP-MHG 3-15FK-e	417	58	211	148	155	62.5	φ10	149	180	151/169.5/198	90	170	70	1/2
TRP-MHG 4-15FK-e	420	61	211	148	155	62.5	φ10	149	180	151/169.5/198	90	170	70	1/2
TRP-MHG 6-15FK-e	425	66	211	148	155	62.5	φ10	149	180	151/169.5/198	90	170	70	1/2
TRP-MHG 8-15FK-e	430	71	211	148	155	62.5	φ10	149	180	151/169.5/198	90	170	70	1/2
TRP-MHG10-15FK-e	435	76	211	148	155	62.5	φ10	149	180	151/169.5/198	90	170	70	3/4
TRP-MHG12-15FK-e	440	81	211	148	155	62.5	φ10	149	180	151/169.5/198	90	170	70	3/4
TRP-MHA14-15FK-e	437	77	212	148	155	62.5	φ10	149	180	153.5/172/200.5	90	170	70	3/4
TRP-MHA16-15FK-e	439	79	212	148	155	62.5	φ10	149	180	153.5/172/200.5	90	170	70	3/4
TRP-MHA18-15FK-e	442	82	212	148	155	62.5	φ10	149	180	153.5/172/200.5	90	170	70	3/4
TRP-MHA20-15FK-e	447	87	212	148	155	62.5	φ10	149	180	153.5/172/200.5	90	170	70	3/4

Assembly drawing

● In the case of 2EK and 4EK

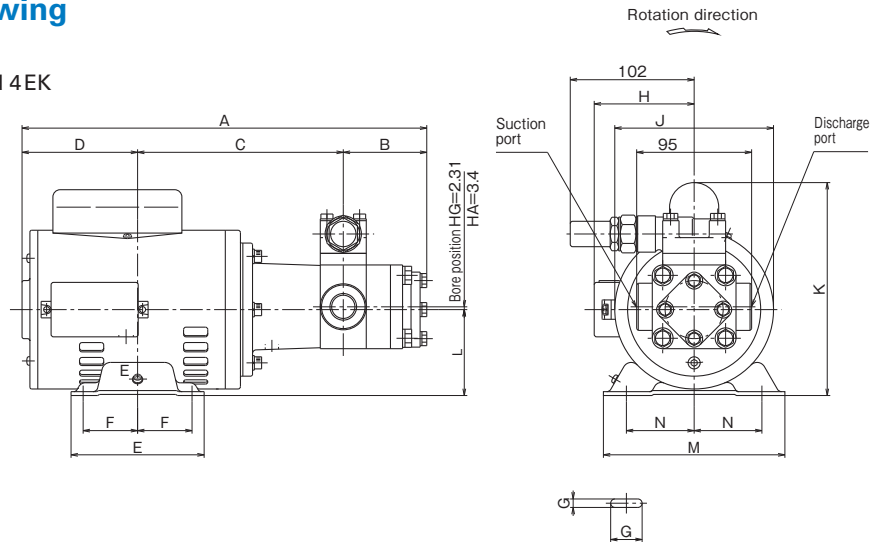

● In the case of 75 SC

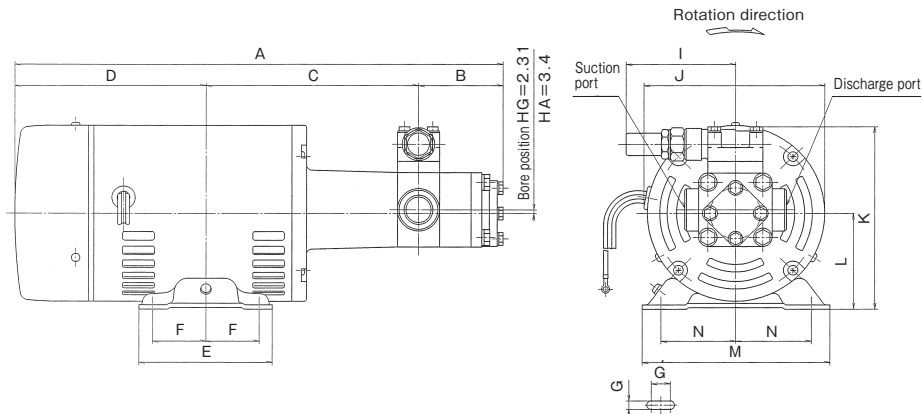

Dimensions

(Unit: mm)

Type	A	B	C	D	E	F	G	H	J	K Without DB/DB/DBT	L	M	N	Bore (Rc) Suction, Discharge
TRP-MHG 3-2EK	324	58	170	96	110	45	7×26	83	131	176/176/179	71	150	56	1/2
TRP-MHG 4-2EK	327	61	170	96	110	45	7×26	83	131	176/176/179	71	150	56	1/2
TRP-MHG 6-2EK	332	66	170	96	110	45	7×26	83	131	176/176/179	71	150	56	1/2
TRP-MHG 8-2EK	337	71	170	96	110	45	7×26	83	131	176/176/179	71	150	56	1/2
TRP-MHG 3-4EK	352	58	178	116	125	50	10×25	80	145	171/171/188	80	160	62.5	1/2
TRP-MHG 4-4EK	355	61	178	116	125	50	10×25	80	145	171/171/188	80	160	62.5	1/2
TRP-MHG 6-4EK	360	66	178	116	125	50	10×25	80	145	171/171/188	80	160	62.5	1/2
TRP-MHG 8-4EK	365	71	178	116	125	50	10×25	80	145	171/171/188	80	160	62.5	1/2
TRP-MHG10-4EK	370	76	178	116	125	50	10×25	80	145	171/171/188	80	160	62.5	3/4
TRP-MHG12-4EK	375	81	178	116	125	50	10×25	80	145	171/171/188	80	160	62.5	3/4
TRP-MHA14-4EK	372	77	179	116	125	50	10×25	80	145	171/171/190.5	80	160	62.5	3/4
TRP-MHA16-4EK	374	79	179	116	125	50	10×25	80	145	171/171/190.5	80	160	62.5	3/4
TRP-MHA18-4EK	377	82	179	116	125	50	10×25	80	145	171/171/190.5	80	160	62.5	3/4
TRP-MHA20-4EK	382	87	179	116	125	50	10×25	80	145	171/171/190.5	80	160	62.5	3/4
TRP-MHG 3-75SC	437	58	200	179	125	50	10×20	—	165.2	151/169.5/198	90	175	70	1/2
TRP-MHG 4-75SC	440	61	200	179	125	50	10×20	—	165.2	151/169.5/198	90	175	70	1/2
TRP-MHG 6-75SC	445	66	200	179	125	50	10×20	—	165.2	151/169.5/198	90	175	70	1/2
TRP-MHG 8-75SC	450	71	200	179	125	50	10×20	—	165.2	151/169.5/198	90	175	70	1/2
TRP-MHG10-75SC	455	76	200	179	125	50	10×20	—	165.2	151/169.5/198	90	175	70	3/4
TRP-MHG12-75SC	460	81	200	179	125	50	10×20	—	165.2	151/169.5/198	90	175	70	3/4
TRP-MHA14-75SC	457	77	201	179	125	50	10×20	—	165.2	153.5/172/200.5	90	175	70	3/4
TRP-MHA16-75SC	459	79	201	179	125	50	10×20	—	165.2	153.5/172/200.5	90	175	70	3/4
TRP-MHA18-75SC	462	82	201	179	125	50	10×20	—	165.2	153.5/172/200.5	90	175	70	3/4
TRP-MHA20-75SC	467	87	201	179	125	50	10×20	—	165.2	153.5/172/200.5	90	175	70	3/4

Features

- ① Maximum discharge pressure: 3.92MPa
- ② Maximum discharge rate: 100L/min
- ③ Ideal for transfer and lubrication.
- ④ Heat resistant type(VT) is available.

Description of types

TRP - HC **L** - - **(L)**
① ② ③ ⑤ ...Standard

- ① Model (HC type)
- ② Discharge rate (30, 40, 50, 65)
- ③ Installation method (F and L)
- ④ Relief valve (Blank: without DB, DB, DBT)
- ⑤ Rotation direction



The photo shows TRP-HC30L-DB.

Please note that the paint color, etc. may partially differ from the photo.

<Precautions for use>

- 1. Use the pump at a rotation speed of 1200 min⁻¹ or lower, whenever possible.
- 2. Please contact us when using kerosene, etc.

Performance curve

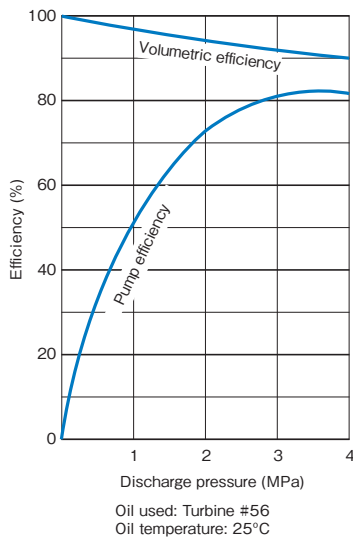

Oil temperature and volumetric efficiency

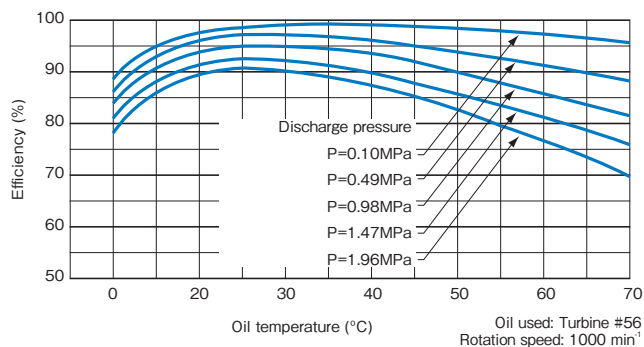

Shaft power (kW) per 1000 min⁻¹

Type	0.98MPa	1.96MPa	2.94MPa	3.92MPa
TRP-HC30L	1.066	1.592	1.951	2.601
TRP-HC40L	1.299	1.733	2.378	3.177
TRP-HC50L	1.733	2.311	3.170	4.227
TRP-HC65L	2.166	2.888	3.963	5.284

Component drawing

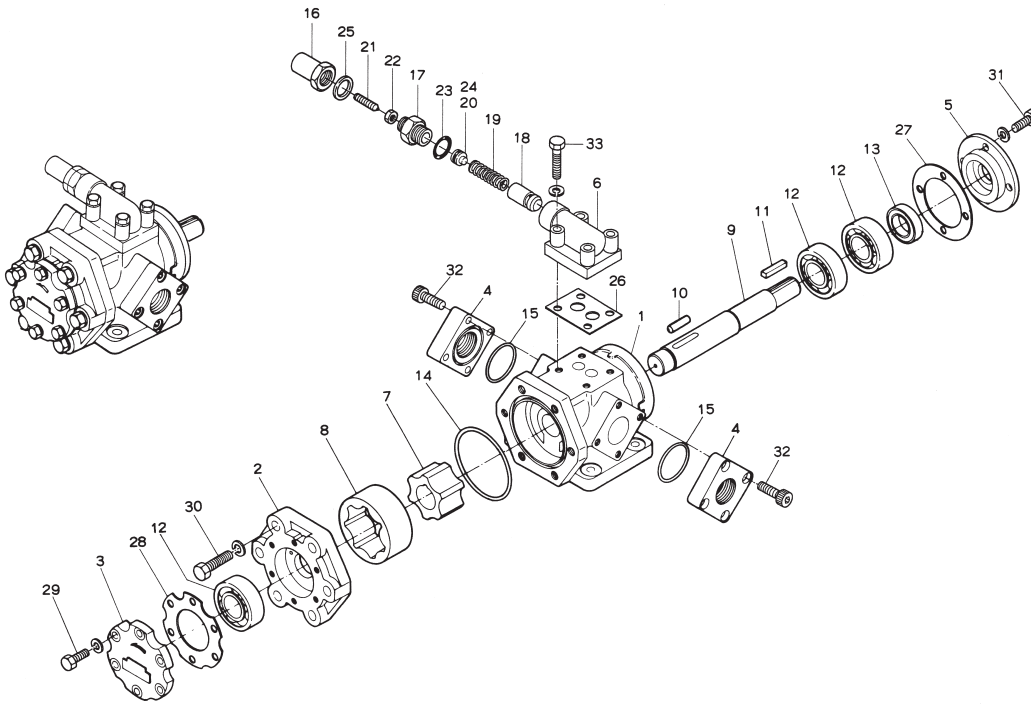

Parts table

No.	Part Name
1	Casing
2	Bearing case
3	Bearing cover
4	Companion flange
5	Seal cover
6	Valve case
7	Inner rotor
8	Outer rotor
9	Shaft
10	Key
11	Key
12	Bearing 6305
13	Oil seal D254511
14	O-ring G85
15	O-ring G45
16	Cap
17	Connector
18	Valve element
19	Spring
20	Spring retainer
21	Adjusting screw
22	Hexagon nut
23	O-ring P18
24	O-ring P10A
25	Sheet packing
26	Sheet packing
27	Sheet packing
28	Sheet packing
29	Hexagon head bolt
30	Hexagon head bolt
31	Hexagon head bolt
32	Hexagon socket head cap screw
33	Hexagon head bolt

TRP-HC



The photo shows TRP-HC30L.

Please note that the paint color, etc. may partially differ from the photo.

Assembly drawing

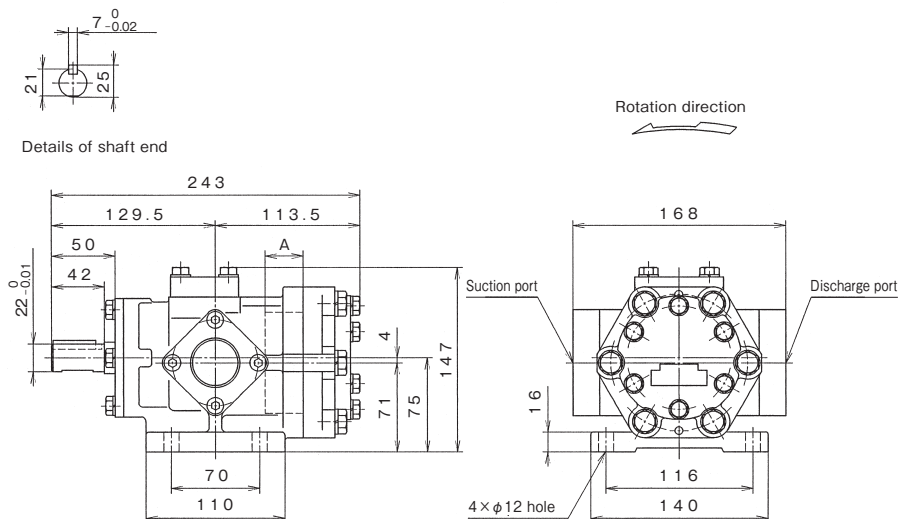

Specifications table

(Unit: mm)

Type	Theoretical discharge rate (L/1000 min ⁻¹)		Maximum discharge pressure (MPa)	Maximum rotation speed (min ⁻¹)	Rotor width A	Bore (Rc)		Approx. mass (kg)
	L/min	L/H				Suction port	Discharge port	
TRP-HC30L	31.8	1908	3.92	1800	25	1¼	1	14.5
TRP-HC40L	38.1	2289	3.92	1800	30	1¼	1	14.5
TRP-HC50L	52.1	3126	3.92	1500	41	1¼	1	14.5
TRP-HC65L	64.8	3892	2.94	1500	51	1¼	1	14.5

TRP-HC-DB

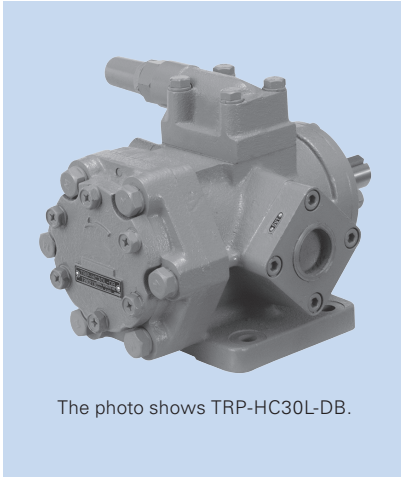

The photo shows TRP-HC30L-DB.

Please note that the paint color, etc. may partially differ from the photo.

Assembly drawing

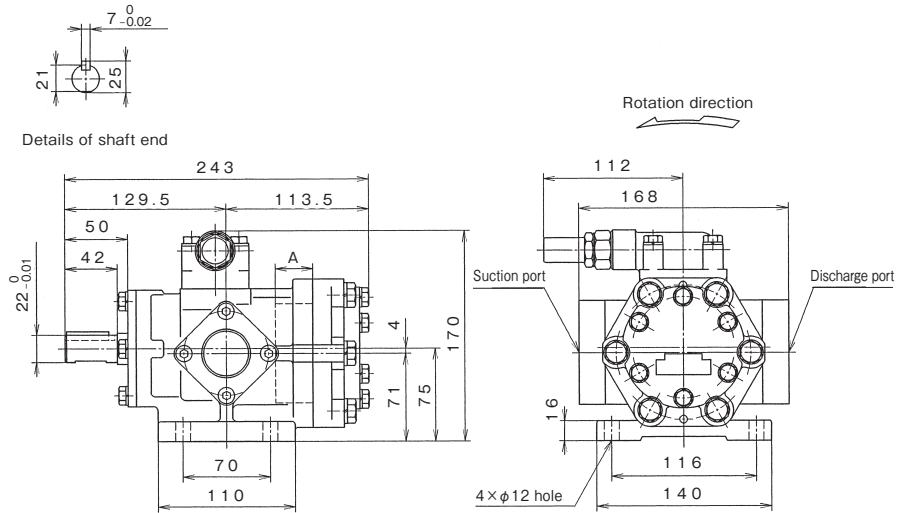

Specifications table

(Unit: mm)

Type	Theoretical discharge rate(L/1000min ⁻¹)		Maximum discharge pressure (MPa)	Maximum rotation speed (min ⁻¹)	Rotor width A	Bore (Rc)		Approx. mass(kg)
	L/min	L/H				Suction port	Discharge port	
TRP-HC30L-DB	31.8	1908	3.92	1800	25	1¼	1	15.0
TRP-HC40L-DB	38.1	2289	3.92	1800	30	1¼	1	15.0
TRP-HC50L-DB	52.1	3126	3.92	1500	41	1¼	1	15.0
TRP-HC65L-DB	64.8	3892	2.94	1500	51	1¼	1	15.5

TRP-HC-DBT

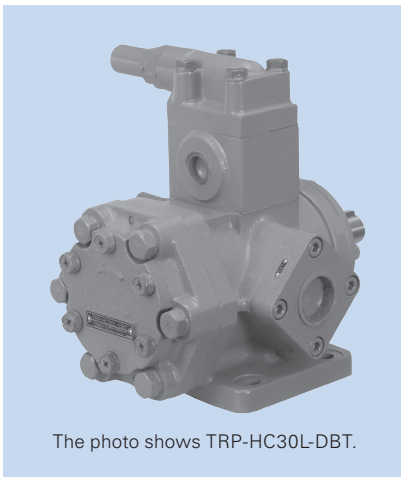

The photo shows TRP-HC30L-DBT.

Please note that the paint color, etc. may partially differ from the photo.

Assembly drawing

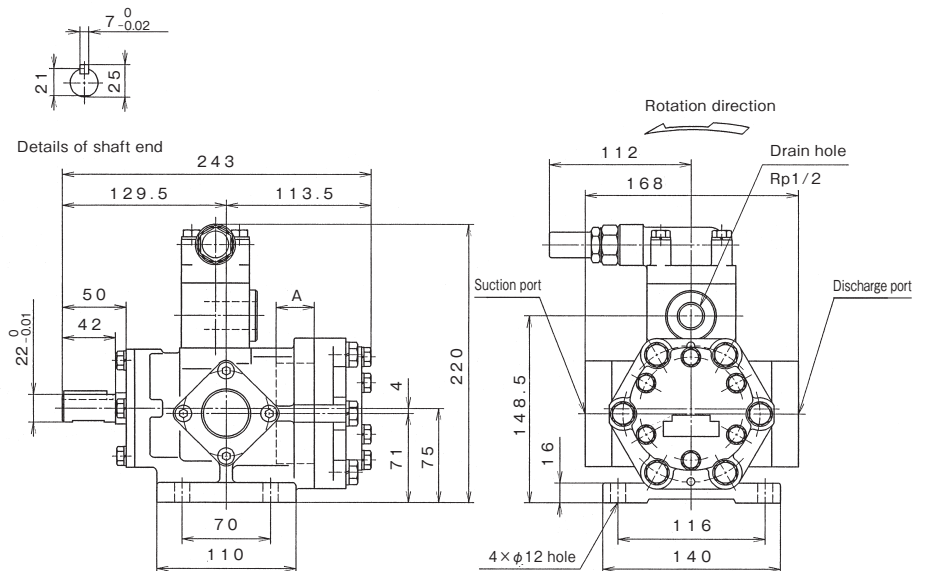

Specifications table

(Unit: mm)

Type	Theoretical discharge rate(L/1000min ⁻¹)		Maximum discharge pressure (MPa)	Maximum rotation speed (min ⁻¹)	Rotor width A	Bore (Rc)		Approx. mass(kg)
	L/min	L/H				Suction port	Discharge port	
TRP-HC30L-DBT	31.8	1908	3.92	1800	25	1¼	1	16.0
TRP-HC40L-DBT	38.1	2289	3.92	1800	30	1¼	1	16.0
TRP-HC50L-DBT	52.1	3126	3.92	1500	41	1¼	1	16.5
TRP-HC65L-DBT	64.8	3892	2.94	1500	51	1¼	1	17.0

Features

- ① In the case of safety explosion-proof and pressure-proof explosion-proof electric motors, the pump is equipped with a base.
- ② Coolant specifications (CL) and thermal specifications (VT) are available.
- *Keep in mind that HC type (for common base) cannot be directly connected to this motor.

Description of types

TRP - M HC - - **FK-** ^(R) _(L) ^{.....Standard}

① ② ③ ④ ⑤ ⑥ ⑦ ⑧ ⑨

- ① Pump with motor
- ② Model (HC type)
- ③ Structure (Blank: motor-integrated, B: with base)
- ④ Discharge rate (30, 40, 50, 65)
- ⑤ Relief valve (Blank: without DB, DB, DBT)
- ⑥ Motor output (0.75kW (75), 1.5kW (15), 2.2kW(22))
With base (0.75kW (0.75), 1.5kW (1.5), 2.2kW (2.2))
- ⑦ Motor specifications (FK), with base: blank
- ⑧ Rotation direction
- ⑨ Motor efficiency (Blank: Standard efficiency (equivalent to IE1),
-e: Top Runner efficiency (equivalent to IE3))



The photo shows TRP-MHC30-DB-22FE.

Please note that the paint color, etc. may partially differ from the photo.

Component drawing

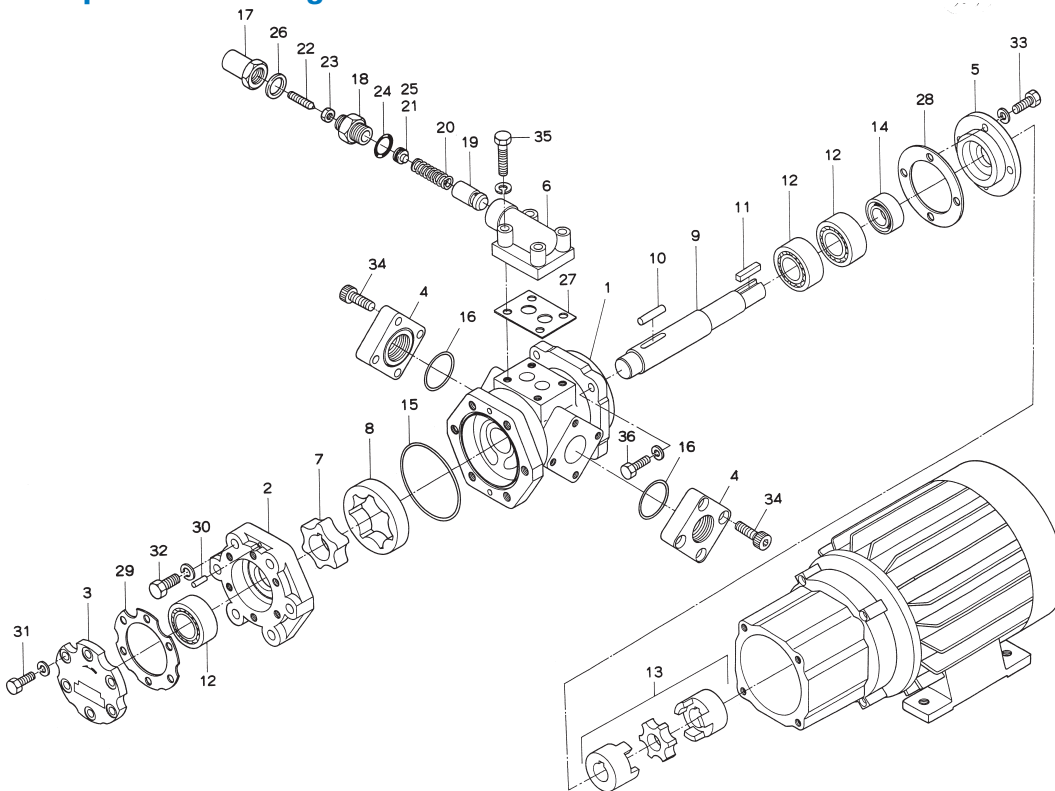

Parts table

No.	Part Name	No.	Part Name	No.	Part Name
1	Casing	13	Coupling	25	O-ring P10A
2	Bearing case	14	Oil seal D254511	26	Sheet packing
3	Bearing cover	15	O-ring G85	27	Sheet packing
4	Companion flange	16	O-ring G45	28	Sheet packing
5	Seal cover	17	Cap	29	Sheet packing
6	Valve case	18	Connector	30	Dowel pin
7	Inner rotor	19	Valve element	31	Hexagon head bolt
8	Outer rotor	20	Spring	32	Hexagon head bolt
9	Shaft	21	Spring retainer	33	Hexagon head bolt
10	Key	22	Adjusting screw	34	Hexagon socket head cap screw
11	Key	23	Hexagon head bolt	35	Hexagon head bolt
12	Ball bearing 6305	24	O-ring P18	36	Hexagon head bolt

TRP-MHC

Assembly drawing

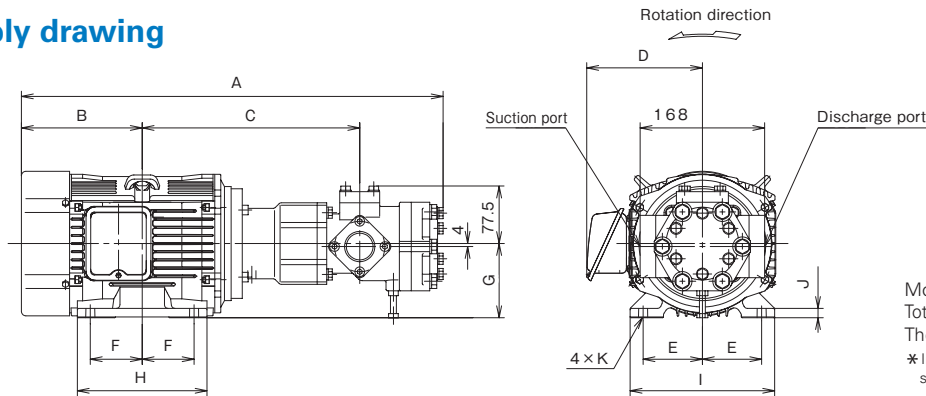

Motor specifications
Totally-enclosed fan-cooled indoor type
Thermal class E, continuous rating
* Inform us any other special specifications
such as special voltage, tropical treatment.

Dimensions

(Unit: mm)

Motor	A	B	C	D	E	F	G	H	I	J	K	Approx. mass (kg)
1.5kW 4P	519	146.5	259.5	149	70	62.5	90	155	170	10	∅10	36.5
2.2kW 4P	569.5	163	293.5	156	80	70	100	175	195	12.5	∅12	46.0

Specifications table

Type	Bore (Rc)		Number of poles 4P					
			1500 min ⁻¹ (50Hz)			1800 min ⁻¹ (60Hz)		
			Suction	Discharge	Theoretical discharge rate (L/min)	Maximum discharge ressure(MPa)		Theoretical discharge rate (L/min)
1.5kW	2.2kW	1.5kW				2.2kW		
TRP-MHC30	1¼	1	47.7	0.88	1.96	57.2	0.29	1.47
TRP-MHC40	1¼	1	57.2	0.29	1.47	68.6	—	0.88
TRP-MHC50	1¼	1	78.2	—	0.69	93.8	—	0.49
TRP-MHC65	1¼	1	97.3	—	0.49	116.7	—	—

TRP-MHC-DB

Assembly drawing

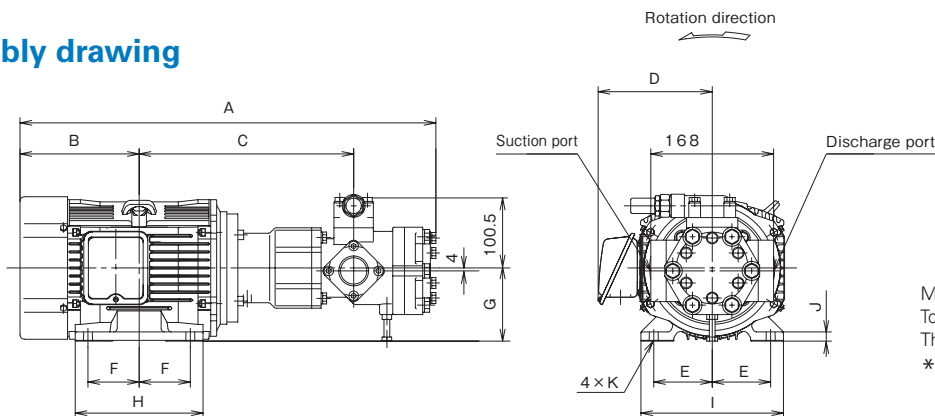

Motor specifications
Totally-enclosed fan-cooled indoor type
Thermal class E, continuous rating
* Inform us any other special specifications
such as special voltage, tropical treatment.

Dimensions

(Unit: mm)

Motor	A	B	C	D	E	F	G	H	I	J	K	Approx. mass (kg)
1.5kW 4P	519	146.5	259.5	149	70	62.5	90	155	170	10	∅10	37.0
2.2kW 4P	569.5	163	293.5	156	80	70	100	175	195	12.5	∅12	46.5

Specifications table

Type	Bore (Rc)		Number of poles 4P					
			1500 min ⁻¹ (50Hz)			1800 min ⁻¹ (60Hz)		
			Suction	Discharge	Theoretical discharge rate (L/min)	Maximum discharge ressure(MPa)		Theoretical discharge rate (L/min)
1.5kW	2.2kW	1.5kW				2.2kW		
TRP-MHC30	1¼	1	47.7	0.88	1.96	57.2	0.29	1.47
TRP-MHC40	1¼	1	57.2	0.29	1.47	68.6	—	0.88
TRP-MHC50	1¼	1	78.2	—	0.69	93.8	—	0.49
TRP-MHC65	1¼	1	97.3	—	0.49	116.7	—	—

TRP-MHC-DBT

Assembly drawing

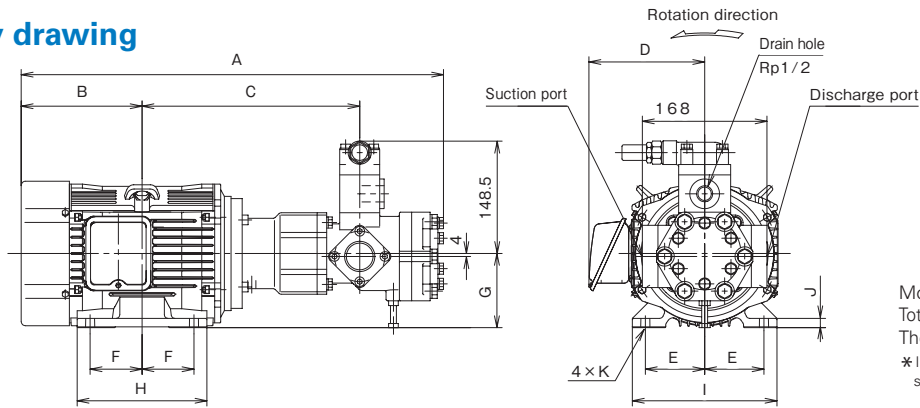

Motor specification
 Totally-enclosed fan-cooled indoor type
 Thermal class E, continuous rating
 * Inform us any other special specifications
 such as special voltage, tropical treatment.

Specification table

(Unit: mm)

Motor	A	B	C	D	E	F	G	H	I	J	K	Approx. mass (kg)
1.5kW 4P	519	146.5	259.5	149	70	62.5	90	155	170	10	φ10	38.0
2.2kW 4P	569.5	163	293.5	156	80	70	100	175	195	12.5	φ12	47.5

Specification table

Type	Bore (Rc)		Number of poles 4P							
			1500 min ⁻¹ (50Hz)			1800 min ⁻¹ (60Hz)				
			Suction	Discharge	Theoretical discharge rate (L/min)	Maximum discharge ressure(MPa)		Theoretical discharge rate (L/min)	Maximum discharge ressure(MPa)	
						1.5kW	2.2kW		1.5kW	2.2kW
TRP-MHC30-DBT	1¼	1	47.7	0.88	1.96	57.2	0.29	1.47		
TRP-MHC40-DBT	1¼	1	57.2	0.29	1.47	68.6	—	0.88		
TRP-MHC50-DBT	1¼	1	78.2	—	0.69	93.8	—	0.49		
TRP-MHC65-DBT	1¼	1	97.3	—	0.49	116.7	—	—		

TRP-MHCB(-DB/-DBT)



The photo shows TRP-MHCB30-DB-2.2.

Please note that the paint color, etc. may partially differ from the photo.

*For an assembly drawing with a base, please contact us.

Specification table

Type	Bore (Rc)		Number of poles 6P								Number of poles 4P											
			1000 min ⁻¹ (50Hz)				1200 min ⁻¹ (60Hz)				1500 min ⁻¹ (50Hz)				1800 min ⁻¹ (60Hz)							
			Suction	Discharge	Theoretical discharge rate (L/min)		Maximum discharge ressure(MPa)		Theoretical discharge rate (L/min)		Maximum discharge ressure(MPa)		Theoretical discharge rate (L/min)		Maximum discharge ressure(MPa)		Theoretical discharge rate (L/min)		Maximum discharge ressure(MPa)			
					0.75kW	1.5kW	2.2kW	3.7kW	0.75kW	1.5kW	2.2kW	3.7kW	0.75kW	1.5kW	2.2kW	3.7kW	0.75kW	1.5kW	2.2kW	3.7kW	5.5kW	
TRP-MHCB30	1¼	1	31.8	0.29	1.96	3.24	3.92	38.1	0.20	1.57	2.65	3.92	47.7	0.88	1.96	3.63	3.92	57.2	0.29	1.47	3.04	3.92
TRP-MHCB40	1¼	1	38.1	0.20	1.47	2.65	3.92	45.7	—	0.98	2.06	3.73	57.2	0.29	1.47	3.04	3.92	68.6	—	0.88	2.35	3.73
TRP-MHCB50	1¼	1	52.1	—	0.96	1.77	3.43	62.5	—	0.29	1.27	2.84	78.2	—	0.69	2.06	3.33	93.8	—	0.49	1.57	2.75
TRP-MHCB65	1¼	1	64.8	—	0.49	1.27	2.65	77.8	—	—	0.69	2.06	97.3	—	0.49	1.47	2.65	116.7	—	—	0.98	2.06

Features

The oil flow direction of the reversible B type pump stays constant even if left rotation and right rotation are alternately changed.
(Ideal for forced lubrication of various machine tools, lubrication of various refrigerators, etc.)

Description of types

TRP - B _ Y
① ②

- ① Model (B type)
- ② Discharge rate (12 , 20, 27)



The photo shows TRP-B20Y.

Please note that the paint color, etc. may partially differ from the photo.

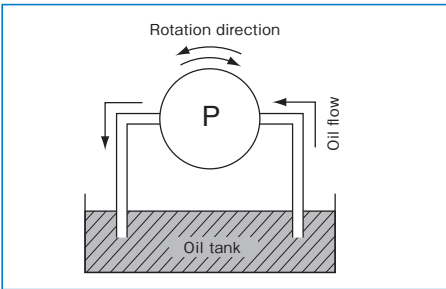

Assembly drawing

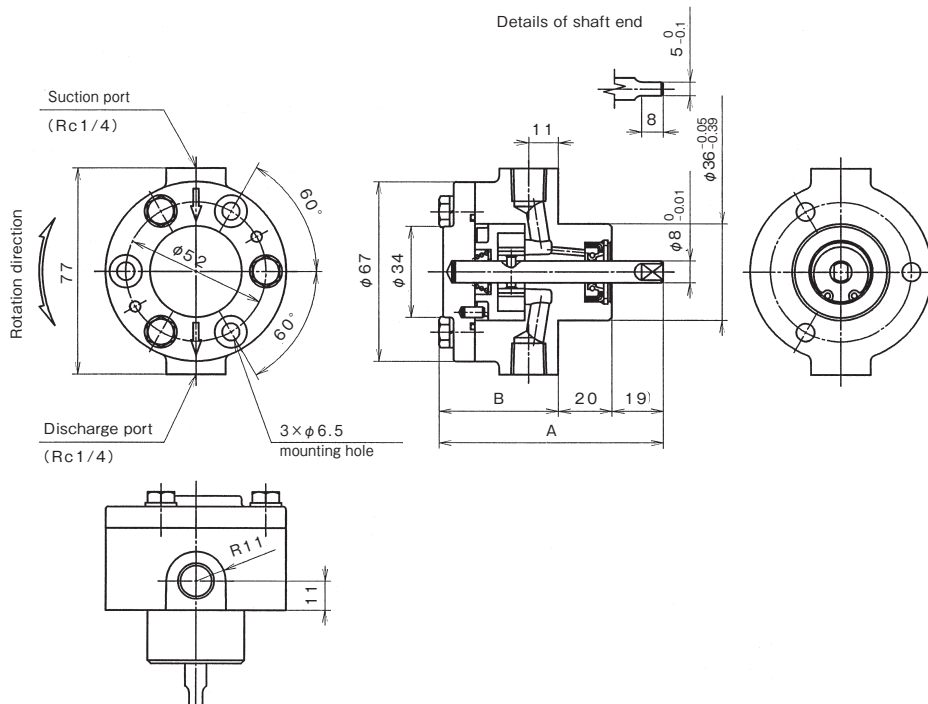

Specification and dimensions table

(Unit: mm)

Type	Theoretical discharge rate (L/1000min ⁻¹)	Maximum discharge pressure (MPa)	Maximum rotation speed (min ⁻¹)	A	B	Bore (Rc)		Approx. mass (kg)
						Suction port	Discharge port	
TRP-B12Y	1.2	0.49	2000	81	42	1/4	1/4	1.0
TRP-B20Y	1.8	0.49	2000	84	45	1/4	1/4	1.1
TRP-B27Y	2.7	0.49	2000	89	50	1/4	1/4	1.2

Features

A reversible pump equivalent to HG type

Description of types

TRP - BH
① ②

- ① Model (BH type)
- ② Discharge rate (4-12)

Performance curve

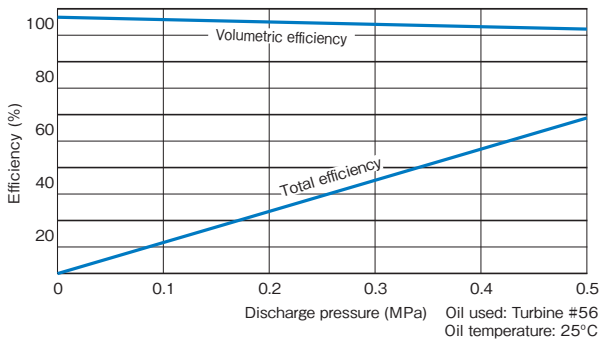

The photo shows TRP-BH8.

Please note that the paint color, etc. may partially differ from the photo.

Shaft power (kW) per 1000min⁻¹

Type	0.10MPa	0.29MPa	0.49MPa	0.98MPa
TRP-BH4	0.051	0.079	0.083	0.111
TRP-BH6	0.099	0.120	0.124	0.166
TRP-BH8	0.133	0.159	0.166	0.222
TRP-BH10	0.166	0.199	0.208	0.277
TRP-BH12	0.199	0.240	0.249	0.333

Assembly drawing

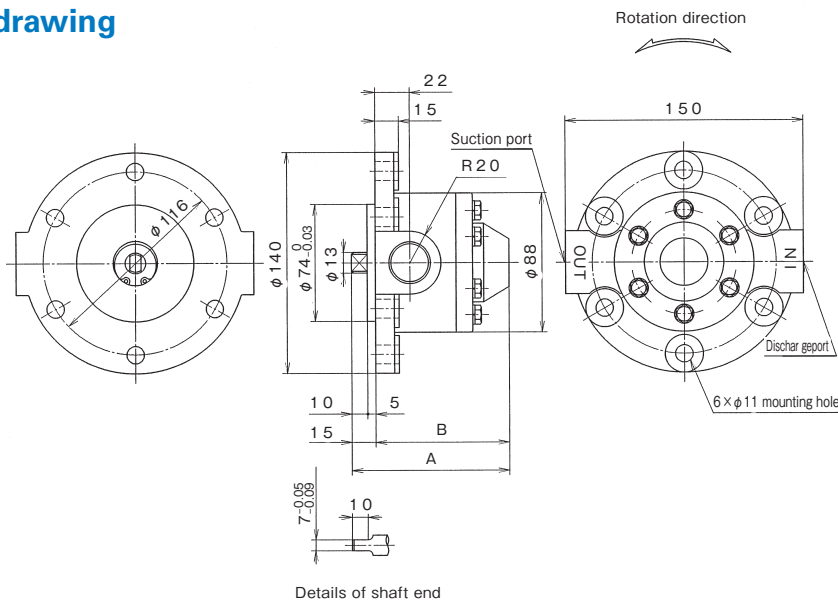

Specification and dimensions table

(Unit: mm)

Type	Theoretical discharge rate (L/1000min ⁻¹)	Maximum discharge pressure (MPa)	Maximum rotation speed (min ⁻¹)	A	B	Bore (Rc)		Approx. mass (kg)
						Suction port	Discharge port	
TRP-BH4	4.5	0.98	2500	93.5	78.5	1/2	3/8	3.7
TRP-BH6	6.6	0.98	2500	98.5	83.5	1/2	1/2	3.9
TRP-BH8	8.7	0.98	2500	103.5	88.5	3/4	1/2	4.0
TRP-BH10	10.4	0.98	2500	108	93	3/4	3/4	4.2
TRP-BH12	12.5	0.98	2500	113	98	3/4	3/4	4.4

Features

- ① Designed for high discharge pressure
- ② The maximum discharge pressure of 1.96MPa
- ③ Because a ball bearing is used for the shaft, gear drive and pulley drive are available.

Description of types

TRP - E **L** - (L) **(R)** ...Standard
 ① ② ③ ④

- ① Model (E type)
- ② Discharge rate
- ③ Installation method
- ④ Rotation direction

Performance curve

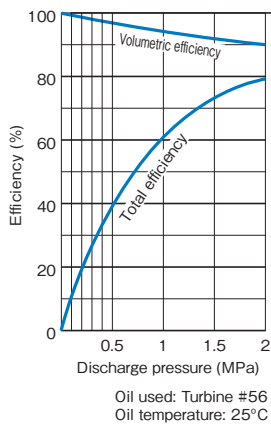

Oil temperature and volumetric efficiency

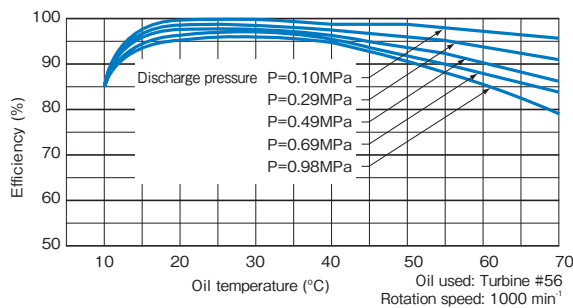

Shaft power (kW) per 1000min⁻¹

Type	0.10MPa	0.29MPa	0.49MPa	0.69MPa	0.98MPa
TRP-E18	0.030	0.036	0.037	0.042	0.049
TRP-E27	0.045	0.054	0.056	0.063	0.075
TRP-E39	0.064	0.078	0.081	0.090	0.108

Component drawing

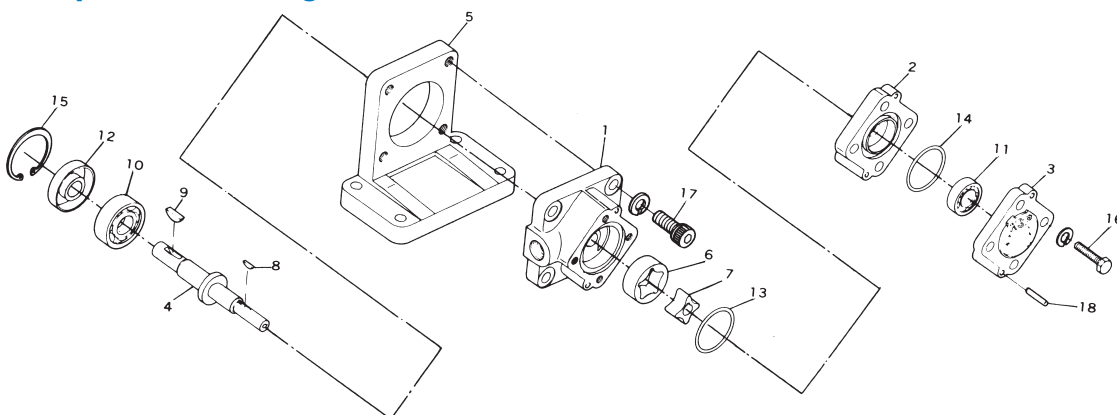

Parts table

No.	Part Name	No.	Part Name	No.	Part Name
1	Casing	7	Inner rotor	13	O-ring 2×32×36
2	Bearing case	8	Key	14	O-ring S26
3	Bearing cover	9	Key	15	Retaining ring
4	Shaft	10	Ball bearing 6201	16	Hexagon head bolt
5	Mounting legs	11	Ball bearing 608	17	Hexagon socket head cap screw
6	Outer rotor	12	Oil seal D12327	18	Dowel pin

TRP-E



The photo shows TRP-E27.

Please note that the paint color, etc. may partially differ from the photo.

Assembly drawing

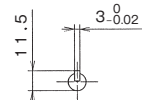

Details of shaft end

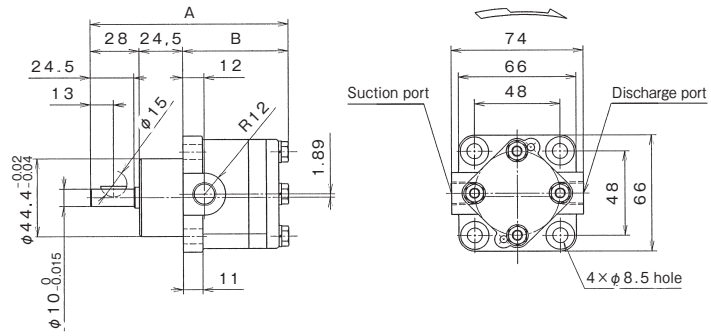

Specification and dimensions table

(Unit: mm)

Type	Theoretical discharge rate (L/1000min ⁻¹)	Maximum discharge pressure (MPa)	Maximum rotation speed (min ⁻¹)	A	B	Rotor width	Bore (Rc)		Approx. mass (kg)
							Suction port	Discharge port	
TRP-E18	1.8	1.96	2000	108	55.5	10	1/4	1/4	1.2
TRP-E27	2.7	1.96	2000	113	60.5	15	1/4	1/4	1.2
TRP-E39	4.0	1.47	2000	119	66.5	22	3/8	3/8	1.3

TRP-EL



The photo shows TRP-EL27L.

Please note that the paint color, etc. may partially differ from the photo.

Assembly drawing

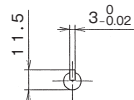

Details of shaft end

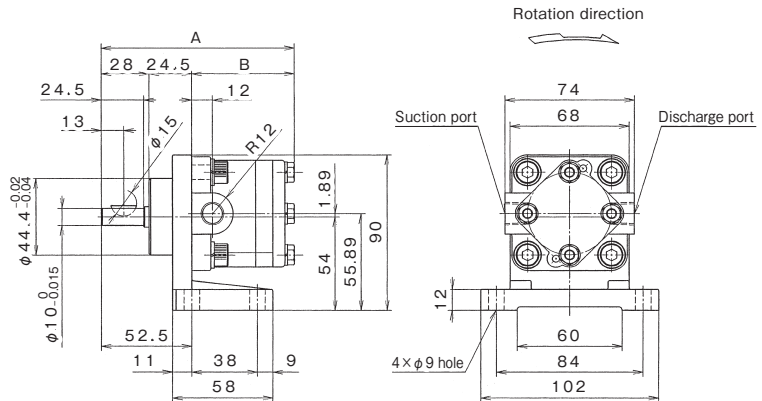

Specification and dimensions table

(Unit: mm)

Type	Theoretical discharge rate (L/1000min ⁻¹)	Maximum discharge pressure (MPa)	Maximum rotation speed (min ⁻¹)	A	B	Rotor width	Bore (Rc)		Approx. mass (kg)
							Suction port	Discharge port	
TRP-E18L	1.8	1.96	2000	108	55.5	10	1/4	1/4	2.0
TRP-E27L	2.7	1.96	2000	113	60.5	15	1/4	1/4	2.0
TRP-E39L	4.0	1.47	2000	119	66.5	22	3/8	3/8	2.1

Features

This type is most appropriate for mechanical design in a limited space because of its small size, light weight, low noise and stable discharge rate.

The mounting of a standard product is a flange type.

- ① Single-phase 100V, 3-phase 200/220V
- ② 3-phase special voltage (380V, etc.) available

Description of types

TRP - MS03 (L) - (DB) (L)

① ② ③ ④ ⑤ Standard

- ① Pump with motor
- ② Discharge rate
- ③ Installation method
- ④ Relief valve (Blank: without DB, DB)
- ⑤ Rotation direction



The photo shows TRP-MS03L-DB.

Please note that the paint color, etc. may partially differ from the photo.

Performance curve

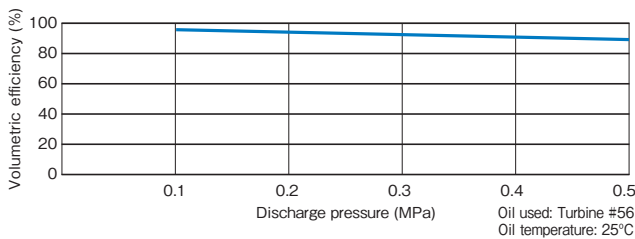

Oil temperature and volumetric efficiency

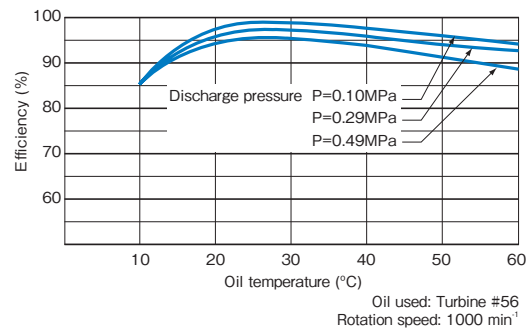

Assembly drawing

● TRP-MS

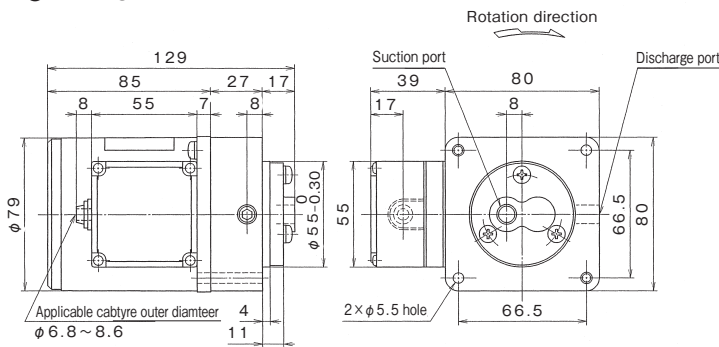

● TRP-MSL-DB

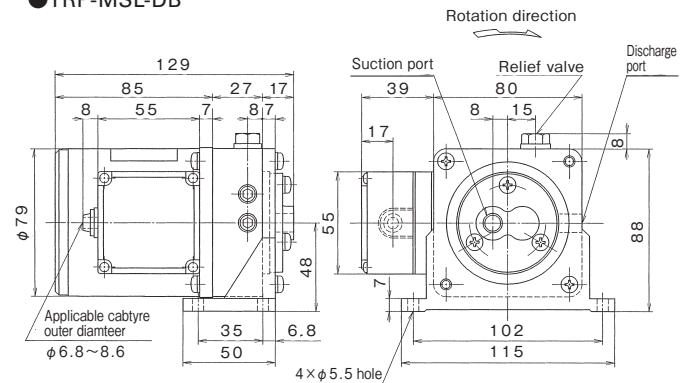

Specification table

(Unit: mm)

Type	Output (W)	Theoretical discharge rate (L/min)		Maximum discharge pressure (MPa)	Bore (Rc)		Approx. mass (kg)
		50Hz	60Hz		Suction port	Discharge port	
TRP-MS03 (-DB)	25	0.45	0.54	0.49	1/8	1/8	2.3
TRP-MS05 (-DB)	25	0.75	0.90	0.49	1/8	1/8	2.3

*These dimensional outline drawing and specification are available for 3-phase type. For the single-phase type, please contact us.

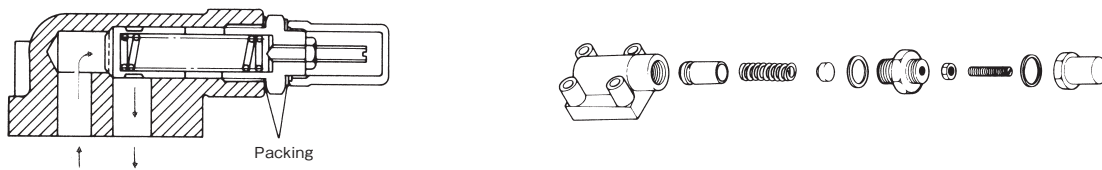

The TR type relief valve is a spring direct-acting relief valve. The set pressure can be adjusted by the combination of a built-in spring and the adjusting screw.

1 Pressure setting

(i) Use as a safety valve

A valve is used to prevent the overload of a motor and other equipment.

In this case, set the pressure to the working pressure + 0.2 – 0.3 MPa.

* The characteristics such as pressure override vary depending on the viscosity and flow rate of use oil.

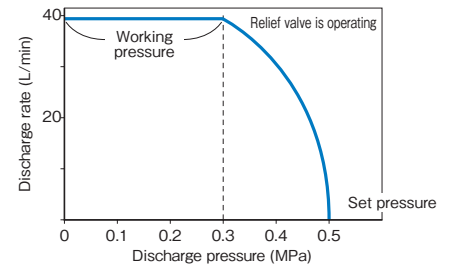

2 Use section of relief valve

(i) Use as a safety valve --- DB (Internal bypass)

○ Ideal for prevention of overload because it is a pump-integrated type.

(ii) Use as a safety valve and a pressure-adjusting valve --- DBT (External bypass)

This is a type with a block for external bypass installed on DB.

○ This is ideal when it is necessary to bypass the entire flow rate for a long time (when pushing up and fixing a cylinder for a certain time, etc.).

(iii) Use as a pressure-adjusting valve --- TR-DB (Bypass on a line)

Also, the valve can be used as a hydraulic pressure-adjusting valve to maintain a constant pressure.

* As for the return piping of the relief valve, minimize the resistance (pressure loss) as much as possible.

DB(Internal bypass)

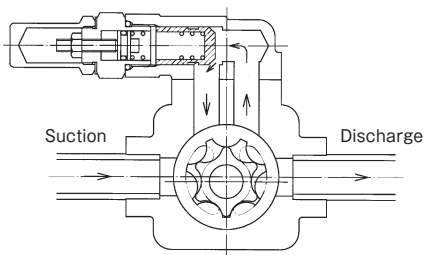

DBT(External bypass)

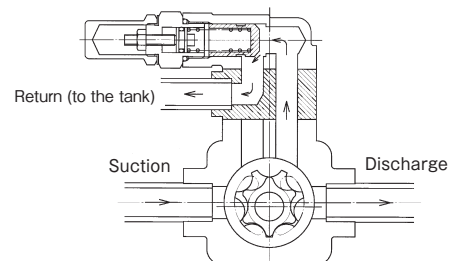

TR-DB

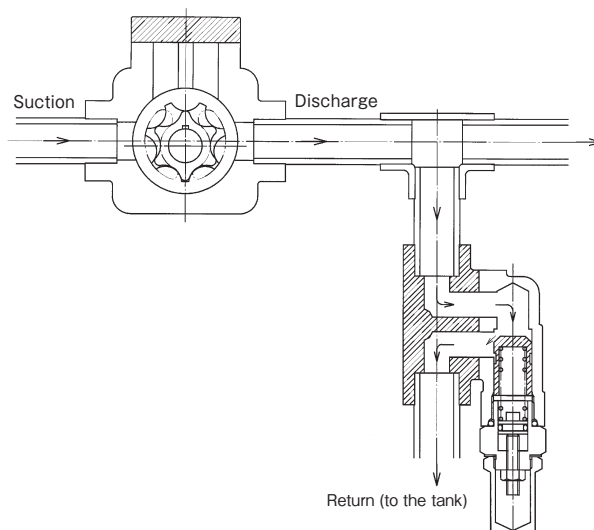

TR-DB-1



Please note that the paint color, etc. may partially differ from the photo.

Assembly drawing

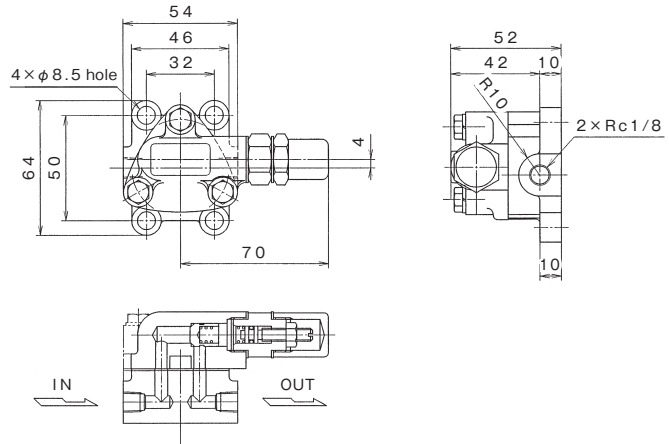

TR-DB-4

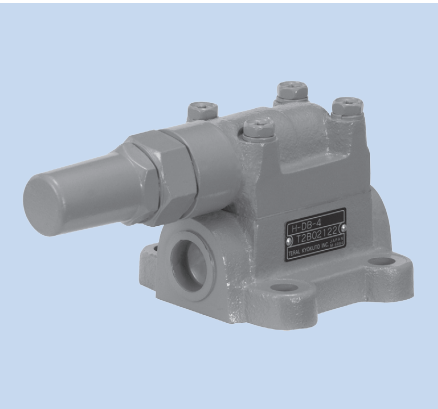

Please note that the paint color, etc. may partially differ from the photo.

Assembly drawing

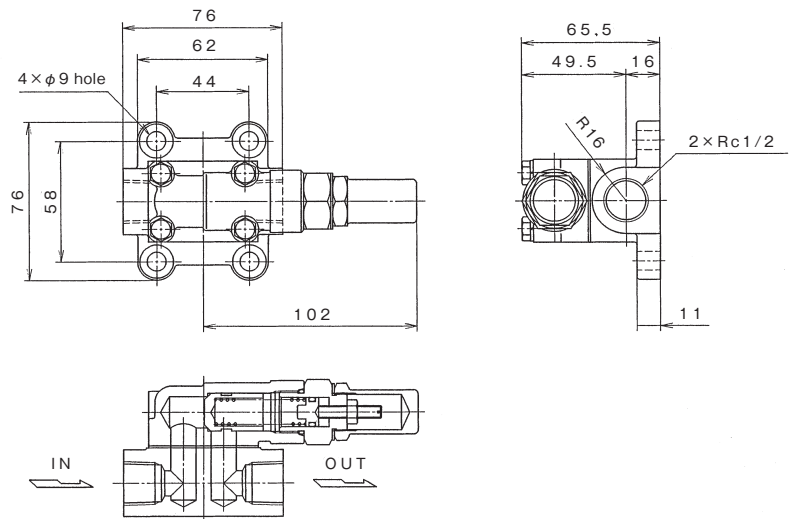

TR-DB-6

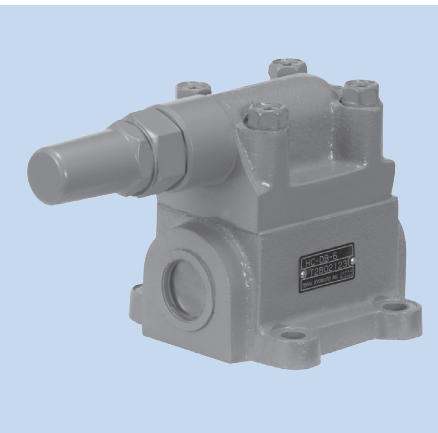

Please note that the paint color, etc. may partially differ from the photo.

Assembly drawing

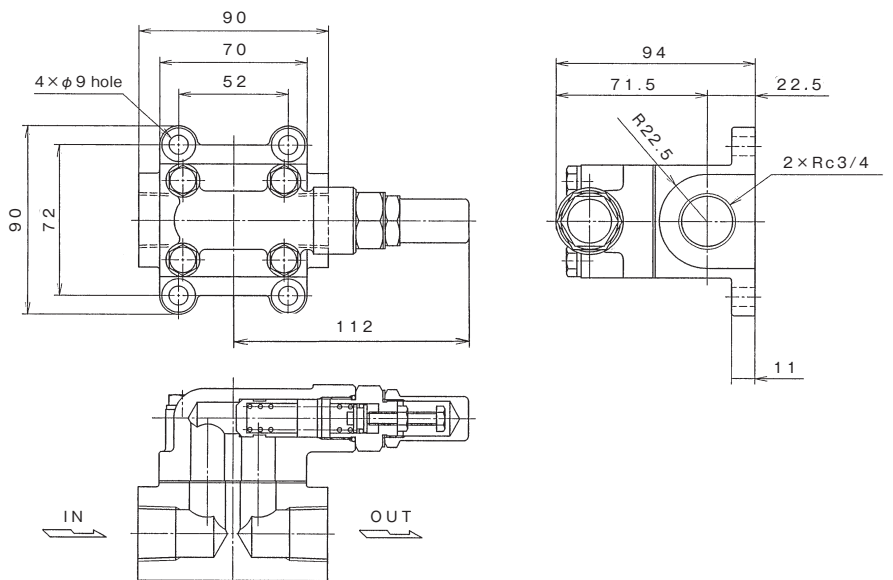

■ Viscosity - Temperature

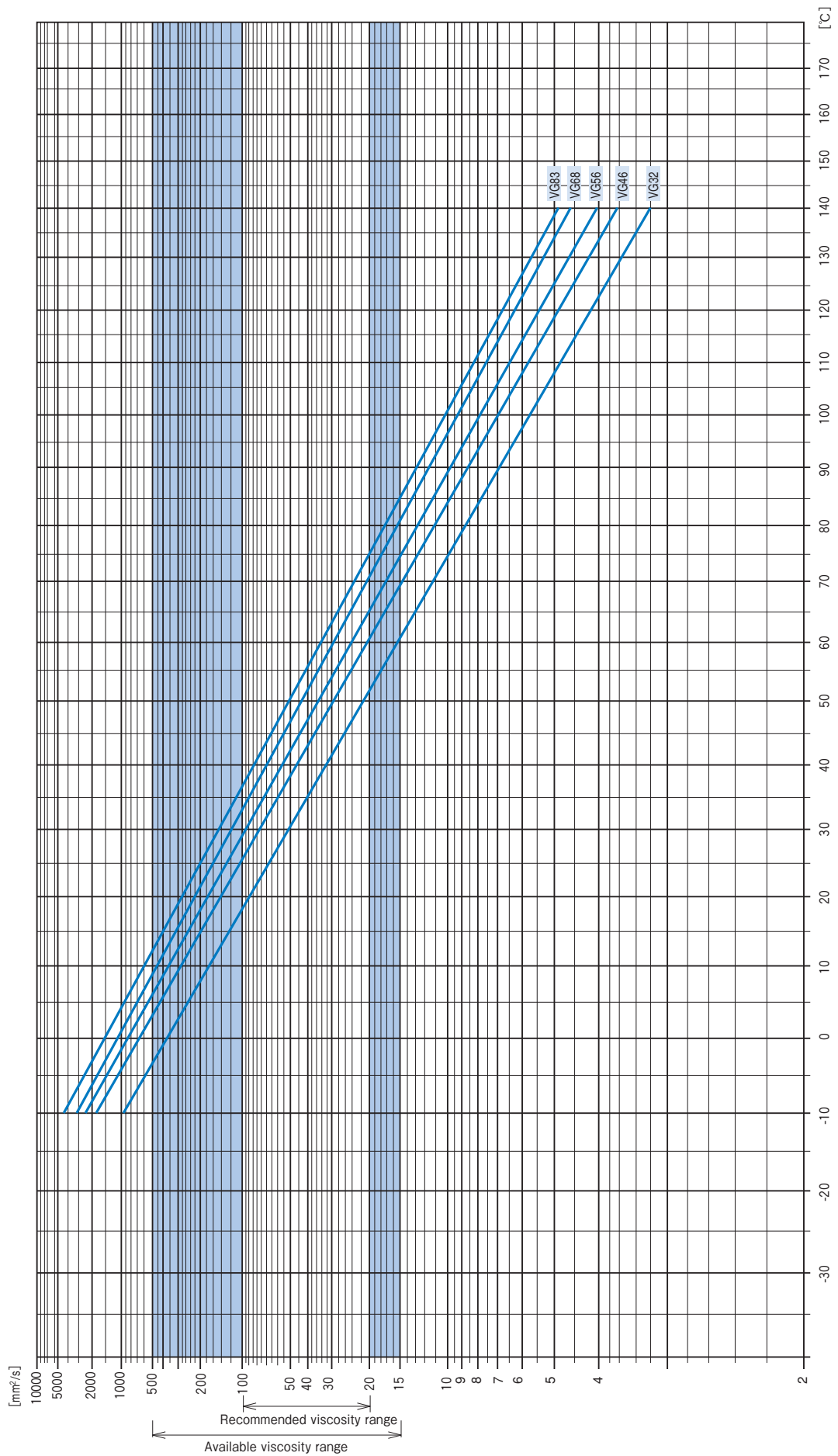

Your Dealer

TERAL

TERAL INC.

Head Office 230, Moriwake, Miyuki-cho, Fukuyama-city, Hiroshima, 720-0003, Japan Tel.+81-84-955-1111 Fax.+81-84-955-5777
www.teral.net

TERAL ASIA LTD.

Room 1001, 10/F, Olympia Plaza, 255 King's Road, North Point, Hong Kong Tel.+852-2571-0886 Fax.+852-2571-0619

TERAL THAI CO., LTD.

TERAL TRADING & SERVICE CO., LTD.

150 Moo 16 Udomsoraryuth Rd., T.Bangkrasan, A.Bangpa-In, Ayutthaya 13160 Thailand Tel.+66-3522-0640 Fax.+66-3522-1259

TERAL GENERAL MACHINE (SHANGHAI) CO., LTD.

No.285, Yuan Qu Road(N), Bei Qiao, Min Hang District, Shanghai 201109, China Tel.+86-21-6490-9128 Fax.+86-21-6490-9126